



# **ELEMENTARY MATHEMATICS BENCHMARKS**

## **GRADES K – 6**

**(organized by strand)**

**Achieve, Inc.**

**May 2008**

## Elementary Mathematics Benchmarks Grades K–6

### (organized by strand)

Topics are arranged in five content strands (Number, Measurement, Probability and Statistics, Geometry, and Algebra) and grade levels K–6. In this view, users can see how each strand progresses across the primary grades.

## Number (N)

### Kindergarten

#### **N.K.1 Count objects and use numbers to express quantity.**

##### **a. Count up to 25 objects and tell how many there are in the counted group of objects.**

**Note:** Accuracy depends on not skipping objects or counting objects twice. Counting objects foreshadows the important mathematical concept of one-to-one correspondence.

**Note:** Going past 20 is important to move beyond the irregular "teen" pattern into the regular twenty-one, twenty-two, ... counting routine.

##### **b. Read aloud numerals 1 through 25 and match numerals with the numbers used in counting.**

**Note:** In early grades "number" generally means "natural number" or, more mathematically, "non-negative integer."

##### **c. Place numbers 1 through 25 in their correct sequence.**

**Note:** The emphasis in kindergarten is on the sequence of numbers as discrete objects. The "number line" that displays continuous connection from one number to the next is introduced in grade 2.

##### **d. Count to 20 by twos.**

- Recognize 20 as two groups of 10 and as 10 groups of two.

##### **e. Recognize and use ordinal numbers (e.g., first, fourth, last).**

Example: The fourth ladybug is about to fly.

#### **N.K.2 Use number notation and place value up to 20.**

##### **a. Understand that numbers 1 through 9 represent "ones."**

##### **b. Understand that numbers 11 through 19 consist of one "ten" and some "ones."**

- Relate the "teen" number words to groups of objects ("ten" + some "ones").  
Example: 13 can be called "one ten and three ones," with "thirteen" being a kind of nickname.

### **N.K.3 Compare numbers up to 10**

#### **a. Compare sets of 10 or fewer objects and identify which are equal to, more than, or less than others.**

- Compare by matching and by counting.
- Use picture graphs (pictographs) to illustrate quantities being compared.

#### **b. Recognize zero (0) as the count of "no objects."**

**Note:** *Zero is the answer to "how many are left?" when all of a collection of objects has been taken away.*

Example: Zero is the number of buttons left after 7 buttons are removed from a box that contains 7 buttons.

### **N.K.4 Understand addition as putting together and subtraction as breaking apart.**

#### **a. Add and subtract single-digit numbers whose total or difference is between 0 and 10.**

- Write expressions such as  $5 + 2$  or  $7 - 3$  to represent situations involving sums or differences of numbers less than 10.

#### **b. Understand "add" as "put together" or "add onto" and solve addition problems with numbers less than 10 whose totals are less than 20.**

- Understand the meaning of addition problems phrased in different ways to reflect how people actually speak.
- Use fingers and objects to add.
- Attach correct names to objects being added.

**Note:** *This is especially important when the objects are dissimilar. For example, the sum of 3 apples and 4 oranges is 7 fruits.*

#### **c. Understand "subtract" as "break apart" or "take away" and solve subtraction problems using numbers between 1 and 10.**

- Understand the meaning of subtraction problems phrased in different ways to reflect how people actually speak.  
Example:  $7 - 3$  equals the number of buttons left after 3 buttons are removed from a box that contains 7 buttons.
- Recognize subtraction situations involving missing addends and comparison.

- Use fingers, objects, and addition facts to solve subtraction problems.

**d. Express addition and subtraction of numbers between 1 and 10 in stories and drawings.**

- Translate such stories and drawings into numerical expressions such as  $7 + 2$  or  $10 - 8$ .
- Model, demonstrate (act out), and solve stories that illustrate addition and subtraction.

**N.K.5 Compose and decompose numbers 2 through 10.**

**a. Understand that numbers greater than 2 can be decomposed in several different ways.**

**Note:** *Decomposition and composition of single-digit numbers into other single-digit numbers is of fundamental importance to develop meaning for addition and subtraction.*

Example:  $5 = 4 + 1 = 3 + 2$ ;  $10 = 9 + 1 = 8 + 2 = 7 + 3 = 6 + 4 = 5 + 5$ .

- Recognize 6 through 10 as "five and some ones."

**Note:** *This is an important special case because of its relation to finger counting.*

Example:  $6 = 5 + 1$ ;  $7 = 5 + 2$ ;  $8 = 5 + 3$ ;  $9 = 5 + 4$ ;  $10 = 5 + 5$ .

**Grade 1**

**N.1.1 Understand and use number notation and place value up to 100.**

**a. Count to 100 by ones and tens.**

- Group objects by tens and ones and relate written numerals to counts of the groups by ones, and to counts of the groups by tens.

**b. Read and write numbers up to 100 in numerals.**

- Understand and use numbers up to 100 expressed orally.
- Write numbers up to 10 in words.

**c. Recognize the place value of numbers (tens, ones).**

- Recognize the use of *digit* to refer to the numerals 0 through 9.
- Arrange objects into groups of tens and ones and match the number of groups to corresponding digits in the number that represents the total count of objects.

**N.1.2 Compare numbers up to 100 and arrange them in numerical order.**

**a. Arrange numbers in increasing and decreasing order.**

**b. Locate numbers up to 100 on the discrete number line.**

- Understand that on the number line, bigger numbers appear to the right of smaller numbers.

**Note:** *The discrete number line is not the continuous number line that will be used extensively in later grades, but a visual device for holding numbers in their proper regularly spaced positions. The focus in grades K–2 is on the uniformly spaced natural numbers, not on the line that connects them. However, for simplicity, in these grades the discrete number line is often called the number line.*

- Use the number line to create visual representations of sequences.

Examples: Even numbers, tens, multiples of five.

- Understand and use relational words such as *equal*, *bigger*, *greater*, *greatest*, *smaller*, and *smallest*, and phrases *equal to*, *greater than*, *more than*, *less than*, and *fewer than*.

**c. Compare two or more sets of objects in terms of differences in the number of elements.**

- Use matching to establish a one-to-one correspondence and count the remainder to determine the size of the difference.
- Connect the meanings of relational terms (bigger, etc.) to the order of numbers, to the measurement of quantities (length, volume, weight, time), and to the operations of adding and subtracting.

Example: If you add something bigger, the result is bigger, but if you take away something bigger, the result will be smaller.

**N.1.3 Add, subtract, compose, and decompose numbers up to 100.**

**a. Be able to solve problems that require addition and subtraction of numbers up to 100 in a variety of ways.**

- Know addition and subtraction facts for numbers up to 12.
- Add and subtract efficiently, both mentally and with pencil and paper.

**Note:** *Avoid sums or differences that require numbers greater than 100 or less than 0.*

- Be able to explain why the method used produces the correct answer.

**Note:** *Any correct method will suffice; there is no reason to insist on a particular algorithm since there are many correct methods. Common methods include "adding on" (often using fingers) and regrouping to make a 10.*

Examples:  $6 + 8 = 6 + 4 + 4 = 10 + 4 = 14$ ; or

$$6 + 8 = 8 + 6 = 8 + 2 + 4 = 10 + 4 = 14;$$

- Add three single-digit numbers.

Examples:  $3 + 4 + 1 = ?$ ;  $7 + 5 + 3 = ?$

- Understand and solve oral problems with a variety of phrasing, including *how many more* or *how many fewer*.
- Know how to use a calculator to check answers.

**b. Understand how to compose and decompose numbers.**

- Identify and discuss patterns arising from decompositions.  
Example:  $8 = 7 + 1 = 1 + 7 = 6 + 2 = 2 + 6 = 5 + 3 = 3 + 5 = 4 + 4$ ;  
 $9 = 8 + 1 = 1 + 8 = 7 + 2 = 2 + 7 = 3 + 6 = 6 + 3 = 5 + 4 = 4 + 5$ .
- Represent decomposition situations using terms such as *put together*, *add to*, *take from*, *break apart*, or *compare*.

**c. Use groups of tens and ones to add numbers greater than 10.**

- Using objects or drawings, add the tens, add the ones, and regroup if needed.  
**Note:** *Grouping relies on the commutative and associative properties of addition. Examples in early grades foreshadow more formal treatments later. The vocabulary should await later grades.*

Examples:

(a)  $17 + 24 = 17 + 23 + 1 = 17 + 3 + 20 + 1 = 20 + 20 + 1 = 40 + 1 = 41$ .

(b)  $58 + 40 = 50 + 8 + 40 = 50 + 40 + 8 = 98$

(c)  $58 + 6 = 50 + 8 + 6 = 50 + 14 = 50 + 10 + 4 = 60 + 4 = 64$

(d)  $58 + 26 = (58 + 2) + (26 - 2) = 60 + 24 = 84$ .

**d. Create and solve addition and subtraction problems with numbers smaller than 20.**

- Create and discuss problems using drawings, stories, picture graphs, diagrams, symbols, and open equations (e.g.,  $4 + ? = 17$ ).
- Use the (discrete) number line to illustrate the meaning of addition and subtraction.
- Express answers in a form (verbal or numerical) that is appropriate to the original problem.
- Always check that answers are intuitively reasonable.

## Grade 2

### N.2.1 Understand and use number notation and place value up to 1,000.

**a. Count by ones, twos, fives, tens, and hundreds.**

- Count accurately for at least 25 terms.  
Example: Count by tens from 10 to 200; count by 2s from 2 to 50.

- Begin counts with numbers other than 1.  
Example: Count by tens from 200 to 300; count by 5s from 50 to 100.

**b. Read and write numbers up to 1,000 in numerals and in words.**

- Up to 1,000, read and write numerals and understand and speak words; write words up to 100.

**c. Recognize the place values of numbers (hundreds, tens, ones).**

- Understand the role of zero in place value notation.  
Example: In  $508 = 5$  hundreds,  $0$  tens, and  $8$  ones, the  $0$  tens cannot be ignored (even though it is equal to zero), because in place value notation, it is needed to separate the hundreds position from the ones position.

**Note:** *Grade 2 begins the process of numerical abstraction--of dealing with numbers beyond concrete experience. Place value, invented in ancient India, provides an efficient notation that makes this abstract process possible and comprehensible.*

**d. Understand and utilize the relative values of the different number places.**

- Recognize that the hundreds place represents numbers that are 10 times as large as those in the tens place and that the units place represents numbers that are 10 times smaller than those in the tens place.

**Note:** *Understanding these relative values provides the foundation for understanding rounding, estimation, accuracy, and significant digits.*

- Use meter sticks and related metric objects to understand how the metric system mimics the "power of 10" scaling pattern that is inherent in the place value system.  
Example: Write lengths, as appropriate, in centimeters, decimeters, meters, and kilometers.

**e. Compare numbers up to 1,000.**

**N.2.2 Locate and interpret numbers on the number line.**

**a. Recognize the continuous interpretation of the number line where points correspond to distances from the origin (zero).**

- Know how to locate zero on the number line.

**Note:** *The number line is an important unifying idea in mathematics. It ties together several aspects of number, including size, distance, order, positive, negative, and zero. Later it will serve as the basis for understanding rational and irrational numbers and after that for the limit processes of calculus. In grade 2 the interpretation of the number line advances from discrete natural numbers to a continuous line of indefinite length in both directions. Depending on context, a number  $N$  (e.g., 1 or 5) can be thought of either as a single point on the number line, or as the interval connecting the point 0 to the point  $N$ , or as the length of that interval.*

**b. Use number line pictures and manipulatives to illustrate addition and subtraction as the adding and subtracting of lengths.**

**Note:** *A meter stick marked in centimeters is a useful model of the number line because it reflects the place value structure of the decimal number system.*

**c. Understand the symbol  $\frac{1}{2}$  and the word *half* as signifying lengths and positions on the number line that are midway between two whole numbers.**

- Read foot and inch rulers with uneven hash marks to the nearest half inch.

**N.2.3 Add, subtract, and use numbers up to 1,000.**

**a. Add and subtract two- and three-digit numbers with efficiency and understanding.**

- Add and subtract mentally with ones, tens, and hundreds.
- Use different ways to regroup or ungroup (decompose) to efficiently carry out addition or subtraction both mentally and with pencil and paper.  
Example:  $389 + 492 = (389 - 8) + (8 + 492) = 381 + 500 = 881$
- Perform calculations in writing and be able to explain reasoning to classmates and teachers.
- Add three two-digit numbers in a single calculation.
- Before calculating, estimate answers based on the left-most digits; after calculating, use a calculator to check the answer.

**b. Understand "related facts" associated with adding and subtracting.**

**Note:** *The expression "related facts" refers to all variations of addition and subtraction facts associated with a particular example.*

- Solve addition equations with unknowns in various positions.  
Example:  $348 + 486 = ?$ ,  $348 + ? = 834$ ,  $? + 486 = 834$ ,  $834 - 486 = ?$ ,  
 $834 - ? = 348$ , and  $? - 486 = 348$ .
- Demonstrate how carrying (in addition) and borrowing (in subtraction) relate to composing and decomposing (or grouping and ungrouping).
- Connect the rollover cases of carrying in addition to the remote borrowing cases in subtraction.  
Example:  $309 + 296 = 605$ ;  $605 - 296 = 309$ .

**c. Create stories, make drawings, and solve problems that illustrate addition and subtraction with unknowns of various types.**

- Understand situations described by phrases such as *put together* or *add to* (for addition) and *take from*, *break apart*, or *compare* (for subtraction).
- Recognize and create problems using a variety of settings and language.



**Caution:** *Avoid being misled by (or dependent on) stock phrases such as more or less as signals for adding or subtracting.*

**d. Solve problems that require more than one step and that use numbers below 50.**

**Note.** *Since the challenge here is to deal with multi-step problems, the numbers are limited to those already mastered in the previous grade.*

- Solve problems that include irrelevant information and recognize when problems do not include sufficient information to be solved.
- Represent problems using appropriate graphical and symbolic expressions.
- Express answers in verbal, graphical, or numerical form, using appropriate units.
- Check results by estimation for reasonableness and by calculator for accuracy.

**N.2.4 Understand multiplication as repeated addition and division as the inverse of multiplication.**

**a. Multiply small whole numbers by repeated addition.**

- Skip count by steps of 2, 3, 4, 5, and 10 and relate patterns in these counts to multiplication.  
Example:  $3 \times 4$  is the 3rd number in the sequence 4, 8, 12, 16, 20, . . . .
- Relate multiplication by 10 to the place value system.

**b. Understand division as the inverse of multiplication.**

- Use objects to represent division of small numbers.  
**Note:** *As multiplication is repeated addition, so division is repeated subtraction. Consequently, division reverses the results of multiplication and vice versa.*  
**Note:** *Since division is defined here as the inverse of multiplication, only certain division problems make sense, namely those that arise from a multiplication problem.*  
Example:  $8 \div 4$  is 2 since  $4 \times 2 = 8$ , but  $8 \div 3$  is not (yet) defined.

**c. Know the multiplication table up to  $5 \times 5$ .**

- Use multiplication facts within the  $5 \times 5$  table to solve related division problems.  
**Note:** *Multiplication facts up to  $5 \times 5$  are easy to visualize in terms of objects or pictures, so introducing them in grade 2 lays the foundation for the more complex  $10 \times 10$  multiplication expectation that is central to grade 3.*

**d. Solve multiplication and division problems involving repeated groups and arrays of small whole numbers.**

- Arrange groups of objects into rectangular arrays to illustrate repeated addition and subtraction.

- Rearrange arrays to illustrate that multiplication is commutative.

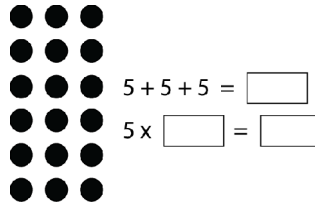
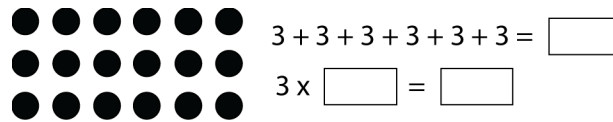

- Demonstrate skip counting on the number line and then relate this representation of repeated addition to multiplication.

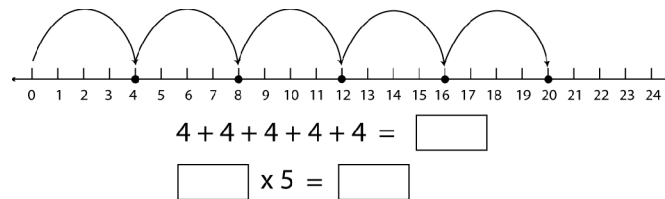

### Grade 3

#### N.3.1 Read, write, add, subtract, and comprehend five-digit numbers.

a. Read and write numbers up to 10,000 in numerals and in words.

b. Understand that digits in numbers represent different values depending on their location (place) in the number.

- Identify the thousands, hundreds, tens, and ones positions, and state what quantity each digit represents.

Example:  $9,725 - 9,325 = 400$  because  $7 - 3 = 4$  in the hundreds position.

c. Compare numbers up to 10,000.

- Understand and use the symbols  $<$ ,  $\leq$ ,  $>$ ,  $\geq$  to signify order and comparison.
- Note especially the distinction between  $<$  and  $\leq$  and between  $>$  and  $\geq$ .

Example: There are 6 numbers that could satisfy  $97 < ? \leq 103$ , but only five that could satisfy  $97 < ? < 103$ .

d. Understand and use grouping for addition and ungrouping for subtraction.

- Recognize and use the terms *sum* and *difference*.

- Use parentheses to signify grouping and ungrouping.

$$\begin{aligned}\text{Example: } 375 + 726 &= (3 + 7) \times 100 + (7 + 2) \times 10 + (5 + 6) \\ &= 10 \times 100 + 9 \times 10 + 10 + 1 = 10 \times 100 + 10 \times 10 + 1 \\ &= (1 \times 1000) + (1 \times 100) + 0 \times 10 + 1 = 1101.\end{aligned}$$

**e. Add and subtract two-digit numbers mentally.**

- Use a variety of methods appropriate to the problem, including adding or subtracting the smaller number by mental (or finger counting); regrouping to create tens; adding or subtracting an easier number and then compensating; creating mental pictures of manual calculation; and others.
- Check answers with a different mental method and compare the efficiency of different methods in relation to different types of problems.

**f. Judge the reasonableness of answers by estimation.**

- Use highest order place value (e.g., tens or hundreds digit) to make simple estimates.

**g. Solve a variety of addition and subtraction problems.**

- Story problems posed both orally and in writing.
- Problems requiring two or three separate calculations.
- Problems that include irrelevant information.

**N.3.2 Multiply and divide with numbers up to 10.**

**a. Understand division as an alternative way of expressing multiplication.**

- Recognize and use the terms *product* and *quotient*.
- Express a multiplication statement in terms of division and vice versa.  
Example:  $3 \times 8 = 24$  means that  $24 \div 3 = 8$  and that  $24 \div 8 = 3$ .

**b. Recognize different interpretations of multiplication and division and explain why they are equivalent.**

- Understand multiplication as repeated addition, as area, and as the number of objects in a rectangular array.  
Example: Compare a class with 4 rows of 9 seats, a sheet of paper that is 4 inches wide and 9 inches high, and a picnic with 4 groups of 9 children each. Contrast with a class that has 9 rows of 4 seats, a sheet of paper that is 9 inches wide and 4 inches high, and a picnic that involves 9 groups of 4 children each.
- Understand division as repeated subtraction that inverts or “undoes” multiplication.

- Understand division as representing the number of rows or columns in a rectangular array, as the number of groups resulting when a collection is partitioned into equal groups, and as the size of each such group.

Example: When 12 objects are partitioned into equal groups, 3 can represent either the number of groups (because 12 objects can be divided into three groups of four [4, 4, 4]) or the size of each group (because 12 objects can be divided into four groups of three [3, 3, 3, 3]).

**Note:** *In early grades, use only  $\div$  as the symbol for division—to avoid confusion when the slash (/) is introduced as the symbol for fractions.*

**c. Know the multiplication table up to  $10 \times 10$ .**

- Knowing the multiplication table means being able to quickly find missing values in open multiplication or division statements such as  $56 \div 8 = [ ]$ ,  $7 \times [ ] = 42$ , or  $12 \div [ ] = 4$ .

**Note:** *Knowing by instant recall is the goal, but recalling patterns that enable a correct rapid response is an important early stage in achieving this skill.*

**d. Count aloud the first 10 multiples of each one-digit natural number.**

**e. Create, analyze, and solve multiplication and division problems that involve groups and arrays.**

- Describe contexts for multiplication and division facts.
- Complete sequences of multiples found in the rows and columns of multiplication tables up to 15 by 15.

**f. Make comparisons that involve multiplication or division.**

**N.3.3 Solve contextual, experiential, and verbal problems that require several steps and more than one arithmetic operation.**

**Note:** *Although solving problems is implicit in every expectation (and thus often not stated explicitly), this particular standard emphasizes the important skill of employing two different arithmetical operations in a single problem.*

**a. Represent problems mathematically using diagrams, numbers, and symbolic expressions.**

**b. Express answers clearly in verbal, numerical, or graphical (bar or picture) form, using units whenever appropriate.**

**c. Use estimation to check answers for reasonableness and calculators to check for accuracy.**

**Note:** *Problem selection should be guided by two principles: To avoid excess reliance on verbal skills, use real contexts as prompts as much as possible. And to focus on problem-solving skills, keep numbers simple, typically within the computational expectations one grade earlier.*

### **N.3.4 Recognize negative numbers and fractions as numbers and know where they lie on the number line.**

#### **a. Know that symbols such as $-1$ , $-2$ , $-3$ represent *negative numbers* and know where they fall on the number line.**

- Recognize negative numbers as part of the scale of temperature.
- Use negative numbers to count backwards below zero.
- Observe the mirror symmetry in relation to zero of positive and negative numbers.

**Caution:** *In grade 3, negative numbers are introduced only as names for points to the left of zero on the number line. They are not used in arithmetic at this point (e.g., for subtraction). In particular the minus sign ( $-$ ) prefix on negative numbers should not at this stage be interpreted as subtraction.*

#### **b. Understand that symbols such as $\frac{1}{2}$ , $\frac{1}{3}$ , and $\frac{1}{4}$ represent numbers called *unit fractions* that serve as building blocks for all fractions.**

- Understand that a unit fraction represents the length of a segment that results when the *unit interval* from 0 to 1 is divided into pieces of equal length.

**Note:** *A unit fraction is determined not just by the number of parts into which the unit interval is divided, but by the number of equal parts. For example, in the upper diagram that follows, each of the four line segments represents  $\frac{1}{4}$ , but in the lower diagram none represents  $\frac{1}{4}$ .*

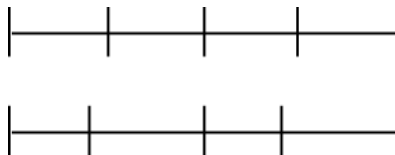

- Recognize, name, and compare unit fractions with denominators up to 10.

Example: The unit fraction  $\frac{1}{6}$  is smaller than the unit fraction  $\frac{1}{4}$  since when the unit interval is divided into 6 equal parts, each part is smaller than if it were divided into four equal parts. The same thing is true of cookies or pizzas: One-sixth of something is smaller than one-fourth of that same thing.

#### **c. Understand that each unit fraction $\frac{1}{n}$ generates other fractions of the form $\frac{2}{n}$ , $\frac{3}{n}$ , $\frac{4}{n}$ . . . , and know how to locate these fractions on the number line.**

- Understand that  $\frac{1}{n}$  is the point to the right of 0 that demarcates the first segment created when the unit interval is divided into  $n$  equal segments. Points marking the

endpoints of the other segments are labeled in succession with the numbers  $\frac{2}{n}, \frac{3}{n}, \frac{4}{n}, \dots$ . These points represent the numbers that are called *fractions*.

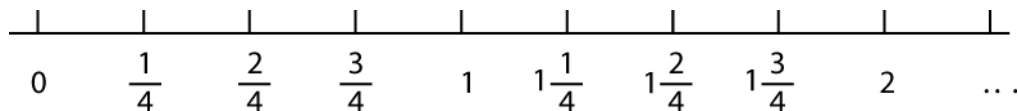

- Understand that a fractional number such as  $\frac{1}{3}$  can be interpreted either as the point that lies one-third of the way from 0 to 1 on the number line or as the length of the interval between 0 and this point.

**Note:** When the unit interval is divided into  $n$  segments, the point to the right of the last ( $n^{\text{th}}$ ) segment is  $\frac{n}{n}$ . This point, the right end-point of the unit interval, is also the number 1.

### N.3.5 Understand, interpret, and represent fractions.

- a. Recognize and utilize different interpretations of fractions, namely, as a *point on the number line*; as a *number that lies between two consecutive (whole) numbers*; as the *length of a segment of the real number line*; and as a *part of a whole*.**

**Note:** The standard of meeting this expectation is not that children be able to explain these interpretations but that they are able to use different interpretations appropriately and effectively.

- b. Understand how a general fraction  $\frac{n}{d}$  is built up from  $n$  unit fractions of the form  $\frac{1}{d}$ .**

- Understand and use the terms *numerator* and *denominator*.
- Understand that the fraction  $\frac{n}{d}$  is a number representing the total length of  $n$  segments created when the unit interval from 0 to 1 is divided into  $d$  equal parts.

**Note:** This definition applies even when  $n > d$  (i.e., the numerator is greater than the denominator): Just lay  $n$  segments of size  $d$  end to end. It will produce a segment of length  $n/d$  regardless of whether  $n$  is less than, equal to, or greater than  $d$ . Consequently, there is no need to require that the numerator be smaller than the denominator.
- Recognize that when  $n = d$ , the fraction  $\frac{n}{d} = 1$ ; when  $n < d$ ,  $\frac{n}{d} < 1$ ; and when  $n > d$ ,  $\frac{n}{d} > 1$ .

Examples:  $\frac{2}{2} = 1$ ,  $\frac{2}{3} < 1$ , and  $\frac{3}{4} > 1$ .

- Recognize the associated vocabulary of *mixed number*, *proper fraction*, and *improper fraction*.

**Note:** *These terms are somewhat archaic and not of great significance. It makes no difference if the numerator of a fraction is larger than the denominator, so there is nothing "improper" about so-called "improper fractions."*

**c. Locate fractions with denominator 2, 4, 8, and 10 on the number line.**

- Understand how to interpret mixed numbers with halves and quarters (e.g.,  $3\frac{1}{2}$  or  $1\frac{1}{4}$ ) and know how to place them on the number line.

**Note:** *Measurement to the nearest half or quarter inch provides a concrete model.*

- Use number lines and rulers to relate fractions to whole numbers.

**Note:** *The denominators 2, 4, and 8 appear on inch rulers and are created by repeatedly folding strips of paper; the denominator 10 appears on centimeter rulers and is central to understanding place value.*

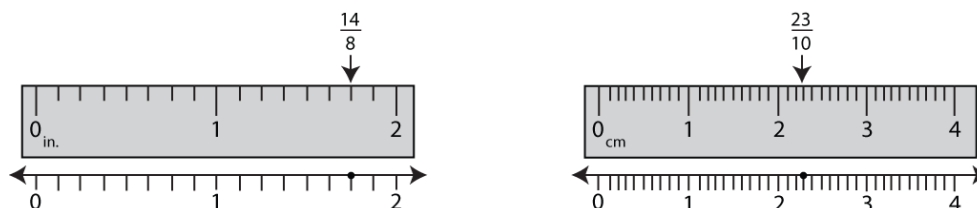

**d. Understand and use the language of fractions in different contexts.**

- When used alone, a fraction such as  $\frac{1}{2}$  is a number or a length, but when used in contexts such as " $\frac{1}{2}$  of an apple" the fraction represents a part of a whole.

**Note:** *A similar distinction also applies to whole numbers: The phrase "I'll take 3 oranges" is not about taking the number 3, but about counting 3 oranges. Similarly, " $\frac{1}{2}$  of an orange" is not about the number (or unit fraction)  $\frac{1}{2}$ , but is a reference to a part of the whole orange.*

**Note:** *The vocalization of unit fractions (one-half, one-third, one-fourth) are expressions children will know from prior experience (e.g., one-half cup of sugar, one-quarter of an hour). Mathematical fractions extend this prior knowledge to numbers by dividing an interval of length 1. In this way, the unit fraction  $\frac{1}{2}$  can be defined as the number representing one-half of the unit interval.*

**e. Recognize fractions as numbers that solve division problems.**

- When the unit interval is divided into equal parts to create unit fractions, the sum of all the parts adds up to the whole interval, or 1. In other words, the total of  $n$  copies of the unit fraction  $\frac{1}{n}$  equals 1. Since division is defined as the inverse of multiplication, this is the equivalent of saying that 1 divided by  $n$  equals  $\frac{1}{n}$ .

Example: Since 4 copies of the unit fraction  $\frac{1}{4}$  combine to make up the unit interval,  $4 \times (\frac{1}{4}) = 1$ . Equivalently,  $1 \div 4 = \frac{1}{4}$ .

**Caution:** At first glance, the statement " $1 \div 4 = \frac{1}{4}$ " might appear to be a tautology.

*It is anything but. Indeed, understanding why this innocuous equation is expressing something of importance is an important step in understanding fractions. The*

*fraction  $\frac{1}{4}$  is the name of a point on the number line, the length of part of the unit interval. The open equation  $1 \div 4 = ?$  asks for a number with the property that  $4 \times ? = 1$ . By observing that the four parts of the unit interval add up to the whole interval, whose length is 1, we discover that the length of one of these parts is the unknown needed to satisfy the equation:  $4 \times \frac{1}{4} = 1$ . This justifies the assertion that*

$$1 \div 4 = \frac{1}{4}.$$

### **N.3.6 Understand how to add, subtract, and compare fractions with equal denominators.**

- a. Recognize how adding and subtracting fractions with equal denominators can be thought of as the joining and taking away, respectively, of contiguous segments on the number line.**

**Note:** Common synonyms for equal denominators are common denominators or like denominators or same denominators. The latter appear to emphasize the form of the denominator (e.g., all 4s), whereas "equal" correctly focuses on what matters, namely, the value of denominator.

- b. Understand that a fraction  $\frac{n}{d}$  is the sum of  $n$  unit fractions of the form  $\frac{1}{d}$ .**

Example:  $\frac{3}{5} = \frac{1}{5} + \frac{1}{5} + \frac{1}{5}$ .

- c. Compare, add, and subtract fractions with equal denominators.**

- Addition and subtraction of fractions with equal denominators work exactly as do addition and subtraction of whole numbers and therefore build on the addition and subtraction of whole numbers.

**Note:** There is no need to simplify answers to lowest terms.



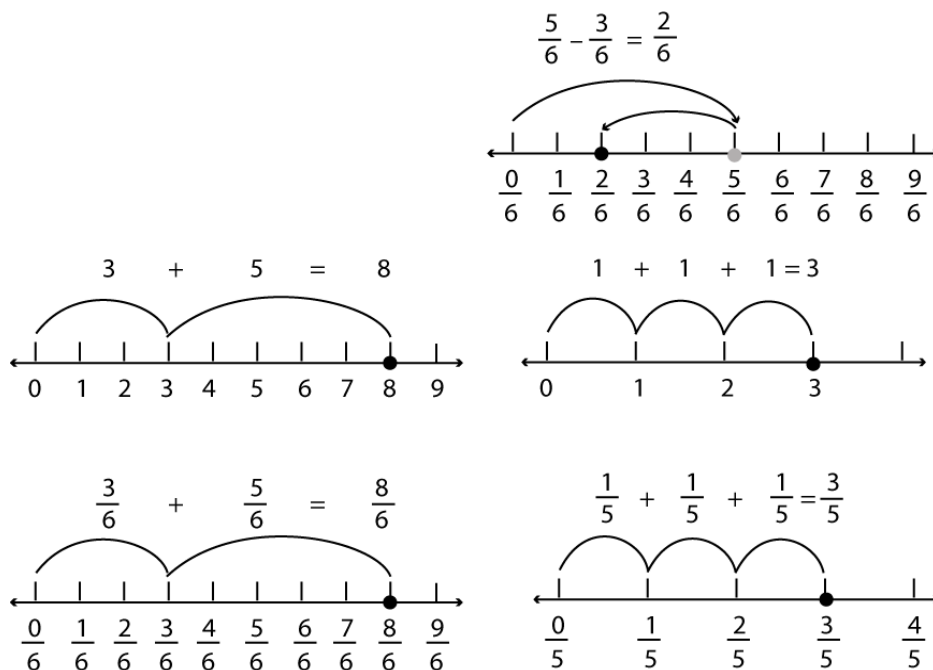

### Grade 4

#### N.4.1 Read, write, add, and subtract positive whole numbers.

a. Read and write numbers in numerals and in words.

b. Recognize the place values in numbers and understand what quantities each digit represents.

- Understand that each digit represents a quantity 10 times as great as the digit to its right.

c. Compare natural numbers expressed in place value notation.

d. Add columns consisting of several three- and four-digit numbers.

- Use and develop skills such as creating tens and adding columns first down then up to ensure accuracy.

Example: The most common example is a list of prices (e.g., a grocery bill or a shopping list).

- Check answers with a calculator.

#### N.4.2 Understand why and how to approximate or estimate.

a. Round off numbers to the nearest 5, 10, 25, 100, or 1,000.

- *Rounding off* is something done to an overly exact number (e.g., a city's population given as 235,461). *Estimation* and *approximation* are actions taken instead of, or as

a check on, an exact calculation. Estimates and approximations are almost always given as round numbers.

*Examples:* In estimating the number of students to be served school lunch, round the number to the nearest 10 students. In estimating a town's population, rounding to the nearest 50 or 100 is generally more appropriate.

**b. Estimate answers to problems involving addition, subtraction, and multiplication.**

**c. Judge the accuracy appropriate to given problems or situations.**

- Use estimation to check the reasonableness of answers.
- Pay attention to the way answers will be used to determine how much accuracy is important.

**Note:** *There are no formal rules that work in all cases. This expectation is about judgment.*

**N.4.3 Identify small prime and composite numbers.**

**a. Understand and use the definitions of prime and composite number.**

- Understand and use the terms *factor* and *divisor*.
- Apply these definitions to identify prime and composite numbers under 50.

**Note:** *A prime number is a natural number that has exactly two positive divisors, 1 and itself. A composite number is a natural number that has more than two divisors. By convention, 1 is neither prime nor composite.*

**b. List all factors of integers up to 50.**

**c. Determine if a one-digit number is a factor of a given integer and whether a given integer is a multiple of a given one-digit number.**

- Find a common factor and a common multiple of two numbers.

**Note:** *Common factors and multiples provide a foundation for arithmetic of fractions and for the concepts of greatest common factor and least common multiple, which are developed in later grades.*

**d. Recognize that some integers can be expressed as a product of factors in more than one way.**

Example:  $12 = 4 \times 3 = 2 \times 6 = 2 \times 2 \times 3$ .

**N.4.4 Multiply small multi-digit numbers and divide by single-digit numbers.**

**a. Understand and use a reliable algorithm for multiplying multi-digit numbers accurately and efficiently.**

- Multiply any multi-digit number by a one-digit number.

- Multiply a three-digit number by a two-digit number.
- Explain why the algorithm works.

Example: Justification of a multiplication algorithm relies on the distributive property applied to place value--an analysis that helps prepare students for algebra. For example, using the distributive property,  $2 \times 35$  can be written as  $2(30 + 5) = 60 + 10 = 70$ . Here's how the analysis applies to a more complex problem:  $258 \times 35$  can be written as  $(200 + 50 + 8) \times 35$ . This becomes:

$$200 \times 35 + 50 \times 35 + 8 \times 35 = 200(30 + 5) + 50(30 + 5) + 8(30 + 5).$$

From this point computations can be done mentally:

$$6000 + 1000 + 1500 + 250 + 240 + 40 = 9030.$$

**b. Understand and use a reliable algorithm for dividing numbers by a single-digit number accurately and efficiently.**

- Explain why the algorithm works.
- Understand division as fair shares and as successive subtraction, and explain how the division algorithm yields a result that conforms with these understandings.
- Check results both by multiplying and by using a calculator.

**c. Recognize, understand, and correct common computational errors.**

Examples: Common errors are displayed below.

$$\begin{array}{r} 26 \\ \times 12 \\ \hline 52 \\ + 26 \\ \hline 78 \end{array}$$

$$\begin{array}{r} 13 \\ 6 \overline{)85} \text{ r}7 \end{array}$$

**d. Understand the role and function of remainders in division.**

- For whole numbers  $a$ ,  $b$ , and  $c$  with  $b \neq 0$ ,
  - when  $a$  is a multiple of  $b$ , the statement  $a \div b = c$  is merely a different way of writing  $a = c \times b$ ;
  - when  $a$  is not a multiple of  $b$ , the division  $a \div b$  is expressed as  $a = c \times b + r$ , where the "remainder"  $r$  is a whole number less than  $b$ .

**N.4.5 Understand and use the concept of equivalent fractions.**



**a. Understand that two fractions are equivalent if they represent the same number.**

**Note:** *Because equivalent fractions represent the same number, we often say, more simply, that they are the same, or equal.*

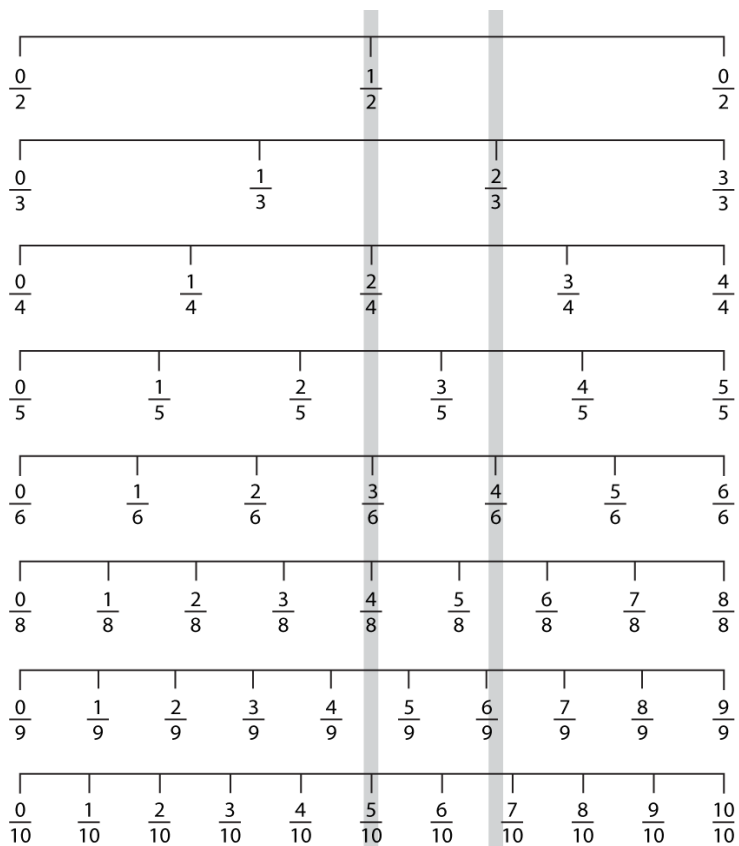
Examples: Just as  $2 + 2$  represents the same number as 4, so  $\frac{4}{6}$  represents the same number as  $\frac{2}{3}$ . The diagram below shows that  $\frac{1}{2} = \frac{2}{4} = \frac{3}{6} = \frac{4}{8} = \frac{5}{10}$  and  $\frac{2}{3} = \frac{4}{6} = \frac{6}{9}$ .

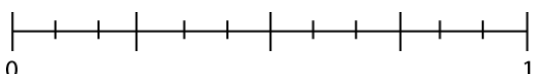

- Illustrate equivalent fractions using small numbers with both length and area.  
Example: Figure 1 demonstrates in two different ways (length and area) how the fact that  $3 \times 3 = 9$  and  $3 \times 4 = 12$  makes  $\frac{3}{4}$  equivalent to  $\frac{9}{12}$ .

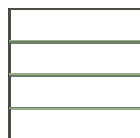
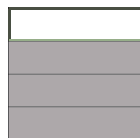
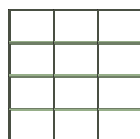
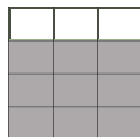
<p><i>Using length to illustrate equivalent fractions:</i></p> <p>Let the whole be the length of a line segment. Divide it into 4 equal parts:</p>  <p>The length of each part represents <math>\frac{1}{4}</math> by the definition of the fraction <math>\frac{1}{4}</math>. Therefore <math>\frac{3}{4}</math> is represented by the length of the thickened line segment, because it has 3 of the 4 equal parts.</p> <p>Divide the length of each equal part of the whole into 3 equal parts:</p>  <p>Here the length of each small line segment represents <math>\frac{1}{12}</math>. Now <math>\frac{3}{4}</math> of the whole takes up 9 of these small line segments:</p>  <p>Therefore the thickened line segment represents <math>\frac{9}{12}</math>. Since the thickened line segment also represents <math>\frac{3}{4}</math>, we see that <math>\frac{3}{4}</math> equals</p> $\frac{3 \times 3}{3 \times 4} = \frac{9}{12}.$	<p><i>Using area to illustrate equivalent fractions:</i></p> <p>Let the whole be the area of a square. Divide it into 4 equal parts:</p>  <p>The area of each part represents <math>\frac{1}{4}</math> by the definition of the fraction <math>\frac{1}{4}</math>. Therefore <math>\frac{3}{4}</math> is represented by the area of the shaded region:</p>  <p>Divide each equal part of the whole into 3 equal parts:</p>  <p>The area of each small rectangle represents <math>\frac{1}{12}</math>. Now <math>\frac{3}{4}</math> of the area of the whole takes up 9 of these small rectangles:</p>  <p>Therefore the shaded area represents <math>\frac{9}{12}</math>. Since the shaded area also represents <math>\frac{3}{4}</math>, we see that <math>\frac{3}{4}</math> equals</p> $\frac{3 \times 3}{3 \times 4} = \frac{9}{12}.$
---	--

**Note:** Adults use three symbols interchangeably to represent division:  $\div$ ,  $/$ , and  $-$ . The latter two are also used interchangeably to represent fractions. Indeed, the symbol  $\frac{2}{3}$  is as often used to represent a fraction as the result of the act of division.

In school, however, since fractions and division are introduced in a specific sequence, it is important that these not be used interchangeably until their equivalence has been well established and rehearsed.

**b. Place fractions on the number line.**

- Understand that equivalent fractions represent the same point on the number line.

**Note:** *As introduced in grade 3, fractions can be interpreted as a point on the number line; as a number that lies between two consecutive whole numbers; as the length of a segment on the real number line; and as a part of a whole. Two fractions are equivalent in each of these interpretations if they refer to the same point, number, length, or part of a whole.*

**c. Understand that any two fractions can be written as equivalent fractions with equal denominators.**

- Use length or area drawings to illustrate these equivalences.

**Note:** *The phrase "like denominator" is often used in this context. However, it is equality, not form or "likeness," that is important.*

Example:  $\frac{1}{3}$  and  $\frac{5}{15}$  are equivalent because both represent one-third of the unit interval. Similarly,  $\frac{1}{5}$  and  $\frac{3}{15}$  are also equivalent because both represent one-fifth of the unit interval.

Example:  $\frac{5}{6}$  is equivalent to  $\frac{5 \times 7}{6 \times 7}$ , and  $\frac{8}{7}$  is equivalent  $\frac{8 \times 6}{7 \times 6}$ , both of which have the same denominators.

**Note:** *More generally,  $\frac{a}{b}$  and  $\frac{c}{d}$  are equivalent to the fractions  $\frac{a \times d}{b \times d}$  and  $\frac{c \times b}{d \times b}$  respectively. This shows a general method for transforming fractions into equivalent fractions with equal (common) denominators.*

**Note:** *The calculations that create equivalent fractions require multiplying both the numerator and the denominator separately, by the same number. This is, of course, the same as multiplying the fraction itself by 1--which is why the two fractions are equivalent. However, it is premature at this stage to suggest that students think of  $\frac{5 \times 7}{6 \times 7}$  as  $\frac{5}{6} \times 1$  because multiplication of fractions by whole numbers is not yet addressed.*

**d. Use equivalent fractions to compare fractions.**

- Use the symbols < and > to make comparisons in both increasing and decreasing order.
- Emphasize fractions with denominators of 10 or less.

Example: The fractions  $\frac{5}{6}$  and  $\frac{3}{8}$  can be compared using the equivalent fractions

$$\frac{5 \times 8}{6 \times 8} \text{ and } \frac{3 \times 6}{8 \times 6}.$$

**N.4.6 Add and subtract simple fractions.**

**a. Add and subtract fractions by rewriting them as equivalent fractions with a common denominator.**

- Solve addition and subtraction problems with fractions that are less than 1 and whose denominators are either (a) less than 10 or (b) multiples of 2 and 10 or (c) multiples of each other.
- Add and subtract lengths given as simple fractions (e.g.,  $\frac{1}{3} + \frac{1}{2}$  inches).
- Find the unknowns in equations such as:  $\frac{1}{8} + [ ] = \frac{5}{8}$  or  $\frac{3}{4} - [ ] = \frac{1}{2}$ .

**Note:** *The idea of common denominator is a natural extension of common multiples introduced above. Addition and subtraction of fractions with common denominators was introduced in grade 3.*

**Note:** *To keep calculations simple, do not use mixed numbers (e.g.,  $3\frac{1}{2}$ ) or sums involving more than two different denominators (e.g.,  $\frac{1}{3} + \frac{1}{2} + \frac{1}{5}$ ). Also, do not stress reduction to a 'simplest' form (because, among many reasons, such forms may not be the simplest to use in subsequent calculations).*

**b. Recognize mixed numbers as an alternate notation for fractions greater than 1.**

- Know how to interpret mixed numbers as an addition.
- Locate mixed numbers on the number line.  
Example:  $\frac{23}{4} = 5\frac{3}{4}$  because on the number line  $\frac{23}{4}$  is  $\frac{3}{4}$  to the right of 5.

**N.4.7 Understand and use decimal numbers up to hundredths.**

**a. Understand decimal digits in the context of place value for terminating decimals with up to two decimal places.**

- A *terminating decimal* is place value notation for a special class of fractions with powers of 10 in the denominators.
- Understand the values of the digits in a decimal and express them in alternative notations.

Examples: The terminating decimal 0.59 equals the fraction  $\frac{59}{100}$ . Similarly, the decimal 12.3 is just another way of expressing the fraction  $\frac{123}{10}$  or the mixed number  $12\frac{3}{10}$ .

**Note:** *Two-place decimals were introduced in grade 3 to represent currency. The concept of two-place decimals as representing fractions with denominator 100 is equivalent to saying that the same amount of money can be expressed either as dollars (\$1.34) or as cents (134¢).*

**Note:** *The denominators of fractions associated with decimal numbers, being powers of 10, are multiples of one another. This makes adding such fractions relatively easy. For example,*

$$2.34 = \frac{234}{100} = \frac{200 + 30 + 4}{100} = \frac{200}{100} + \frac{30}{100} + \frac{4}{100} = \frac{2}{1} + \frac{3}{10} + \frac{4}{100}$$

**b. Add and subtract decimals with up to two decimal places.**

- The arithmetic of decimals becomes arithmetic of whole numbers once they are rewritten as fractions with the same denominator:

$$0.5 + 0.12 = \frac{5}{10} + \frac{12}{100} = \frac{50}{100} + \frac{12}{100} = \frac{50 + 12}{100} = 62 / 100 = .62$$

- Add and subtract two-decimal numbers, notably currency values, in vertical form.

**c. Write tenths and hundredths in decimal and fraction notation and recognize the fraction and decimal equivalents of halves, fourths, and fifths.**

**Note:** *"Thirds" are missing from this list since  $\frac{1}{3}$  cannot be represented by a terminating decimal. This is because no power of 10 is a multiple of three, so the fraction  $\frac{1}{3}$  does not correspond to any terminating decimal.*

**d. Use decimal notation to convert between grams and kilograms, meters and kilometers, and cents and dollars.**

**N.4.8 Solve multi-step problems using whole numbers, fractions, decimals, and all four arithmetic operations.**

**a. Solve problems of various types (mathematical tasks, word problems, contextual questions, and real-world settings) that require more than one of the four arithmetic operations.**

**Note:** *Problem-solving is an implied part of all expectations, but also sometimes worth special attention, as here where all four arithmetic operations are available for the first time. As noted earlier, to focus on strategies for solving problems that are cognitively more complex than those previously encountered, computational demands should be kept simple.*

**b. Understand and use parentheses to specify the order of operations.**

- Know why parentheses are needed, when and how to use them, and how to evaluate expressions containing them.

**c. Use the inverse relation between multiplication and division to check results when solving problems.**

Example: Recognize that  $185 \div 5 = 39$  is wrong because  $39 \times 5 = 195$ .

- Use multiplication and addition to check the result of a division calculation that produces a non-zero remainder.



- d. Translate a problem's verbal statements or contextual details into diagrams and numerical expressions and express answers in appropriate verbal or numerical form, using units as needed.**
- e. Use estimation to judge the reasonableness of answers.**
- f. Create verbal and contextual problems representing a given number sentence and use the four operations to write number sentences for given situations.**

## Grade 5

### **N.5.1 Understand that every natural number can be written as a product of prime numbers in only one way (apart from order).**

#### **a. Extend knowledge of prime and composite numbers up to 100.**

- Write composite numbers up to 100 as a product of prime factors.

**Note:** *Prime and composite numbers were introduced in grade 4. Here the goal is to investigate more examples to develop experience with larger numbers.*

#### **b. Decompose composite numbers into products of factors in different ways and identify which of these combinations are products of prime factors.**

- Recognize that every decomposition into prime factors involves the same factors apart from order.

**Note:** *It is this uniqueness ("the same factors apart from order") of the prime decomposition of integers that makes this fact important--so much so that this result is often called "the fundamental theorem of arithmetic."*

Examples:  $24 = 2 \times 12 = 2 \times 3 \times 4 = 2 \times 3 \times 2 \times 2$ .

$$24 = 3 \times 8 = 3 \times 4 \times 2 = 3 \times 2 \times 2 \times 2.$$

$$24 = 4 \times 6 = 2 \times 2 \times 2 \times 3.$$

### **N.5.2 Know how to divide whole numbers.**

#### **a. Understand and use a reliable algorithm for division of whole numbers.**

- Recognize that the division of a whole number  $a$  by a whole number  $b$  (symbolized as  $a \div b$ ) is a process to find a *quotient*  $q$  and a *remainder*  $r$  satisfying  $a = q \times b + r$ , where both  $q$  and  $r$  are whole numbers and  $r < b$ .

**Note:** *The division algorithm most widely used in the United States is called long division. Although the term itself is often taken to mean division by a two-digit number, the algorithm applies equally well to division of a multi-digit number by a single-digit number.*

- Understand that the long division algorithm is a repeated application of division-with-remainder.

Example: To divide 85 by 6, write  $85 = 80 + 5$ . Dividing 80 by 6 yields 6 10s with 20 left over. In other words,  $85 = 80 + 5 = (10 \times 6) + 20 + 5 = (10 \times 6) + 25$ . In the

long division algorithm, this is written as 6 in the tens place with a remainder of 25. Next, in long division, we divide the remainder, 25, by 6:  $25 = (4 \times 6) + 1$ . Combining both steps yields  $85 = (10 \times 6) + 25 = (10 \times 6) + (4 \times 6) + 1 = (14 \times 6) + 1$ .

$$\begin{array}{r} 14 \\ 6 \overline{) 85} \\ \underline{-60} \\ 25 \\ \underline{-24} \\ 1 \end{array}$$

**Note:** *Since long division is a process in which the same steps are repeated until an answer is obtained, the example just given offers sufficient understanding of the general process.*

**b. Divide numbers up to 1,000 by numbers up to 100 using long division or some comparable approach.**

- Estimate accurately in the steps of the long division algorithm.

Example: To compute  $6,512 \div 27$  requires knowing how many 27s there are in 65, in 111, and in 32.

- Check results by verifying the division equation  $a = q \times b + r$ , both manually and with a calculator.

**c. Know and use mental methods to calculate or estimate the answers to division problems.**

- Mentally divide numbers by 10, one hundred, and one thousand.
- Where possible, break apart numbers before dividing to simplify mental calculations.

**Example:** Divide 49 by 4 by writing  $49 = 48 + 1$ . Since  $48/4 = 12$ ,  $49 \div 4 =$  yields the quotient 12 and remainder 1.

**N.5.3 Understand how to add and subtract fractions.**

**a. Add fractions with unequal denominators by rewriting them as equivalent fractions with equal denominators.**

**Note:** *In grade 4, addition of fractions was restricted to unit fractions, or to those in which one denominator was a multiple of the other. In both cases, these restrictions simplify the required calculations. Here the goal is to understand and learn to do the most general case.*

- Understand and use the general formula  $\frac{a}{b} + \frac{c}{d} = \frac{ad + bc}{bd}$ .

**Note:** *There is no need to find a least common denominator. The easiest common denominator of  $\frac{a}{b}$  and  $\frac{c}{d}$  is most often  $bd$ .*

- When necessary, use calculators to carry out the required multiplications.

$$\begin{aligned} \text{Example: } 17/19 + 13/14 &= [(17 \times 14) + (13 \times 19)] / (19 \times 14) \\ &= (238 + 247) / 266 = 485/266 \end{aligned}$$

**b. Add and subtract mixed numbers.**

$$\text{Example: } 2\frac{1}{15} - 1\frac{3}{4} = \frac{30}{15} + \frac{1}{15} - \frac{4}{4} + \frac{3}{4} = \frac{31}{15} - \frac{7}{4} = \frac{124}{60} - \frac{105}{60} = \frac{19}{60}$$

**c. Find the unknown in simple equations involving fractions and mixed numbers.**

$$\text{Examples: } 2\frac{2}{3} + [ ] = 5\frac{1}{4}; [ ] \times 14 + 3 = 101.$$

**N.5.4 Understand what it means to multiply fractions and know how to do it.**

**a. Understand how multiplying a fraction by a whole number can be interpreted as repeated addition of the fraction.**

$$\text{Example: } 3 \times \frac{2}{5} \text{ can be thought of as } \frac{2}{5} + \frac{2}{5} + \frac{2}{5} = \frac{6}{5}.$$

**Note:** As introduced in grade 3, fractions can be interpreted as a point on the number line; as a number that lies between two consecutive whole numbers; as the length of a segment on the real number line; and as a part of a whole. Defining multiplication of fractions by whole numbers as repeated addition is analogous to how multiplication of whole numbers is understood and readily conforms to the number and length interpretations of fractions.

- In general, if  $a$ ,  $b$ , and  $c$  are whole numbers and  $c \neq 0$ , then  $a \times \frac{b}{c} = \frac{ab}{c}$ .

**Note:** In interpreting multiplication of a fraction by a whole number as repeated addition, we introduce a curious asymmetry.  $3 \times \frac{2}{5}$  is  $\frac{2}{5}$  added to itself three times, but it does not make sense to think of  $\frac{2}{5} \times 3$  as 3 being added to itself  $\frac{2}{5}$  times. This leaves  $\frac{2}{5} \times 3$  undefined under this interpretation. If we were sure that multiplication of fractions is commutative, as is multiplication of whole numbers, then we would be able to say that  $\frac{2}{5} \times 3 = 3 \times \frac{2}{5}$ . But to do this requires the "part of a whole" interpretation of fractions.

Example: The multiplication of a fraction by a whole number can also be interpreted by means of a length or area model. Here's an example of how using an area model for  $3 \times \frac{2}{5}$ . Taking the whole as the area of a unit square,  $3 \times 1$  would be the area of the tower consisting of three unit squares. Since  $\frac{2}{5}$  means dividing the whole into 5

equal parts and taking 2 of them, the sum  $\frac{2}{5} + \frac{2}{5} + \frac{2}{5}$  can be represented by the shaded area in the middle figure on the right. The figure on the far right rearranges the small shaded rectangles to show that  $3 \times \frac{2}{5} = \frac{2}{5} + \frac{2}{5} + \frac{2}{5} = \frac{6}{5}$ .

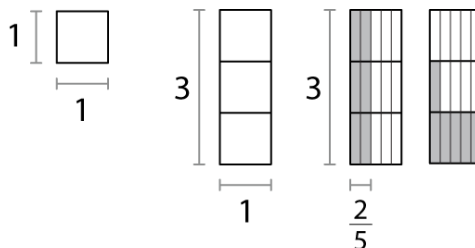

**b. Understand how multiplying two fractions can be interpreted in terms of an area model.**

- Understand why the product of two unit fractions is a unit fraction whose denominator is the product of the denominators of the two unit fractions.

**Note:** Taking the whole to be a unit square, then  $\frac{1}{a} \times \frac{1}{b}$  is by definition the area of a rectangle with length  $\frac{1}{a}$  and width  $\frac{1}{b}$ . In symbols,  $\frac{1}{a} \times \frac{1}{b} = \frac{1}{ab}$ .

**Example:** Let the whole be the area of a unit square. Then  $\frac{1}{2} \times \frac{1}{3}$  is by definition the area of a rectangle with sides of length  $\frac{1}{2}$  and  $\frac{1}{3}$ . The shaded rectangle in this drawing of the unit square is such a rectangle. The shaded area is also  $\frac{1}{6}$  of the area of the whole. Therefore,  $\frac{1}{2} \times \frac{1}{3} = \frac{1}{6}$ .

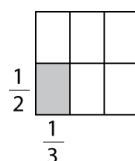

- Interpret the formula  $\frac{a}{b} \times \frac{c}{d} = \frac{ac}{bd}$  in terms of area.

**Note:** If the area of the whole is a unit square, then  $\frac{a}{b} \times \frac{c}{d}$  is by definition the area of a rectangle with length  $\frac{a}{b}$  and width  $\frac{c}{d}$ .

Example: To illustrate the multiplication  $\frac{5}{2} \times \frac{4}{3}$  using area models, let the whole be the area of a unit square. Then  $\frac{1}{2} \times \frac{1}{3}$  is the area of the shaded rectangle with length

of side  $\frac{1}{2}$  and width  $\frac{1}{3}$ . By definition,  $\frac{5}{2} = \frac{1}{2} + \frac{1}{2} + \frac{1}{2} + \frac{1}{2} + \frac{1}{2}$  and  $\frac{4}{3} = \frac{1}{3} + \frac{1}{3} + \frac{1}{3} + \frac{1}{3}$ . These are illustrated in the diagrams on the right. The large rectangle has been made from  $5 \times 4$  copies of the small shaded rectangle shown above. Since  $\frac{1}{2}$  and  $\frac{1}{3}$  are unit fractions, the area of the shaded rectangle is  $\frac{1}{2} \times \frac{1}{3} = \frac{1}{2 \times 3}$ . Therefore, the area of the large rectangle is  $(5 \times 4)/(2 \times 3)$ .

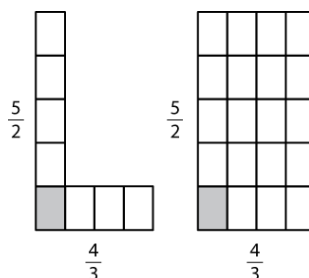

- Recognize that the formula  $\frac{a}{b} \times \frac{c}{d} = \frac{ac}{bd}$  shows that the multiplication of fractions is commutative.

**Note:** By validating commutativity of multiplication, the area model provides the crucial feature that is missing from the "repeated addition" model for multiplication of fractions. This shows that  $\frac{2}{5} \times 3 = 3 \times \frac{2}{5}$ .

**Note:** The formula for multiplying fractions can be used to show that fractions also obey the associative and distributive laws of whole number arithmetic. Experience with examples is sufficient to gain insight into just how this works.

**c. Understand why "a/b of c" is the same as "a/b x c."**

Example: The phrase " $\frac{2}{5}$  of 3" mean  $\frac{2}{5}$  of a whole that is 3 units (e.g.,  $\frac{2}{5}$  of \$3,  $\frac{2}{5}$  of 3 pizzas,  $\frac{2}{5}$  of 3 cups of sugar). To take  $\frac{2}{5}$  of 3 units, take  $\frac{2}{5}$  of each unit and add them together:  $\frac{2}{5} + \frac{2}{5} + \frac{2}{5} = 3 \times \frac{2}{5}$ . Since multiplication of fractions is commutative,  $3 \times \frac{2}{5} = \frac{2}{5} \times 3$ .

Example:  $\frac{3}{4}$  of the length of a 12-inch ruler is 9 inches, while  $\frac{3}{4}$  of the length of a 100-centimeter ruler is 75 centimeters.

**d. Understand that the product of a positive number with a positive fraction less than 1 is smaller than the original number.**

- In symbols, if  $a$ ,  $b$ ,  $c$ , and  $d$  are all  $> 0$  and  $\frac{a}{b} < 1$ , then  $\frac{a}{b} \times \frac{c}{d} < \frac{c}{d}$ .

**Note:** Area is again the easiest model:  $\frac{a}{b} \times \frac{c}{d}$  can be represented by a rectangle with dimensions  $\frac{a}{b}$  and  $\frac{c}{d}$ , whereas  $\frac{c}{d}$  can be represented by a rectangle of dimensions 1 and  $\frac{c}{d}$ . When  $\frac{a}{b} < 1$ , the former will fit inside the latter, thus showing that it has a smaller area.

### N.5.5 Understand and use the interpretation of a fraction as division.

#### a. Understand why the fraction $\frac{a}{b}$ can be considered an answer to the division problem $a \div b$ .

- Among whole numbers, the answer to  $a \div b$  is a quotient and a remainder (which may be zero). Among fractions, the answer to  $a \div b$  is the fraction  $\frac{a}{b}$ .

**Note:** The expression  $a \div b$  where  $a$  and  $b$  are whole numbers signifies a process to find a quotient  $q$  and a remainder  $r$  satisfying  $a = q \times b + r$ , where both  $q$  and  $r$  are whole numbers and  $r < b$ . If we permit fractions as answers, then  $q = \frac{a}{b}$  and  $r = 0$

will always solve the division problem, since  $a = \frac{a}{b} \times b + 0$ .

**Note:** This fact justifies using the fraction bar ( $\frac{\quad}{\quad}$  or  $/$ ) to denote division rather than the division symbol ( $\div$ ). Beyond elementary school, this is the common convention, since the limitation of integer answers (quotient and remainder) is much less common.

Example: To illustrate the assertion that  $\frac{a}{b} = a \div b$  with the fraction  $\frac{3}{4}$ , begin as usual with the whole being a unit square.  $3 \div 4$  is the area of one part when three wholes are divided into 4 equal parts as shown. By moving all three shaded rectangles into the same whole, as shown, they form 3 parts of a whole that has been divided into 4 equal parts. That is the definition of the fraction  $\frac{3}{4}$ . Thus  $3 \div 4 = \frac{3}{4}$ .

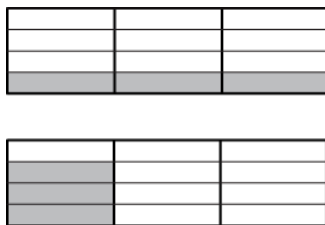

**Note:** Another way to think about the relation between fractions and division is to begin with  $4 \times \frac{3}{4} = 3$ . This says that 4 equal parts, each of size  $\frac{3}{4}$ , make up 3 wholes. Therefore,  $\frac{3}{4}$  is one part when 3 is divided into 4 equal parts--which is one interpretation of  $3 \div 4$ . (This latter interpretation of division is often called "equal shares" or "partitive.")

**b. Understand how to divide a fraction by a fraction and to solve related problems.**

- As with whole numbers, division of fractions is just a different way to write multiplication: If  $A$ ,  $B$ , and  $C$  are fractions with  $B \neq 0$ , then  $\frac{A}{B} = C$  means  $A = C \cdot B$

**Note:** The dot ( $\bullet$ ) is an alternative to the cross ( $\times$ ) as a notation for multiplication. (Computers generally use the asterisk ( $*$ ) in place of a dot.) In written mathematics, but never on a computer, the dot is often omitted (e.g.,  $ab$  means  $a \bullet b$ ). As students move beyond the arithmetic of whole numbers to the arithmetic of fractions and decimals, the symbols  $\bullet$  and  $/$  tend to replace  $\times$  and  $\div$ .

- Divide a fraction  $\frac{a}{b}$  (where  $b \neq 0$ ) by a non-zero whole number  $c$ : because  $\frac{a}{b} = \frac{a}{bc} \times c$ , this division follows the rule  $\frac{a/b}{c} = \frac{a}{bc}$ .

Example:  $\frac{6/7}{4} = \frac{6}{4 \times 7}$  because  $\frac{6}{7} = \frac{6}{4 \times 7} \times 4$ . In the partitive interpretation of division,  $\frac{6/7}{4}$  is one part in a division of  $\frac{6}{7}$  into 4 equal parts.

- Divide a whole number  $a$  by a unit fraction  $\frac{1}{b}$  ( $b \neq 0$ ): because  $a = ab \times \frac{1}{b}$ , this division follows the rule  $\frac{a}{1/b} = ab$ .

Example: Because  $5 = (5 \times 6) \times \frac{1}{6}$ ,  $\frac{5}{1/6} = 5 \times 6$  in the measurement sense of division,  $\frac{5}{1/6} = 5 \times 6$  is the answer to the question "how many parts of size  $\frac{1}{6}$  can 5 be divided into?" Since there are 6 parts of size  $\frac{1}{6}$  in one whole, there are  $5 \times 6$  parts of size  $\frac{1}{6}$  in 5 wholes.

**c. Express division with remainder in the form of mixed numbers.**

- When a division problem  $a \div b$  is resolved into a quotient  $q$  and a remainder  $r$ , then  $a = q \times b + r$ . It follows that  $\frac{a}{b}$  equals the fraction  $\frac{(qb+r)}{b}$ , which in turn equals the mixed number  $= q \frac{r}{b}$ .

Example:  $\frac{37}{7} = \frac{(5 \times 7) + 2}{7} = \frac{(5 \times 7)}{7} + \frac{2}{7} = 5 + \frac{2}{7}$ , which is equal to  $5 \frac{2}{7}$  by definition.

**Note:** Fractions greater than 1 are often called improper fractions, although there is no justification or need for this label.

**d. Understand division as the inverse of multiplication and vice versa.**

**Note:** Division was defined in grade 2 as an action that reverses the results of multiplication. At that time, using only integers, division was limited to composite

numbers and their factors (e.g.,  $6 \div 3$ , but not  $6 \div 4$ ). Only now, using fractions as well as whole numbers, can this inverse relationship be fully understood.

**Note:** Although in previous grades the word "number" meant positive whole number, hereafter it will generally mean positive fraction, which encompasses all whole and mixed numbers.

- For any numbers  $a$  and  $b$  with  $b \neq 0$ ,  $(a \times b) \div b = a$  and  $(a \div b) \times b = a$ . In words, if a number (fraction)  $a$  is first multiplied by  $b$  and then divided by  $b$ , the result is the original number  $a$  and the same is true if we first divide and then multiply.

### **N.5.6 Understand how to multiply terminating decimals by whole numbers.**

#### **a. Multiplying a terminating decimal by a whole number is equivalent to multiplying a fraction by a whole number.**

Example:  $7.53 \times 5 = (753/100) \times 5 = (753 \times 5) / 100 = 3,765/100 = 37.65$ .

#### **b. Understand how to place the decimal point in an answer to a multiplication problem both by estimation and by calculation.**

**Example.**  $5 \times 0.79 = 3.95$  because  $5 \times \frac{79}{100} = \frac{5 \times 79}{100} = \frac{395}{100} = 3.95$ . This can easily be estimated because 0.79 is less than 1, so  $5 \times 0.79$  must be less than 5. Therefore, the answer cannot be 395.0 or 39.5. Similarly, since  $5 > 1$ ,  $5 \times 0.79$  must be greater than .79, so the answer cannot be .395. Thus it must be 3.95.

- When a number is multiplied by a power of 10, the place value of the digits in the number are increased according to the power of 10; the reverse happens when a number is divided by a power of 10.

**Note:** As a consequence, when multiplying a whole number by 10, 100, or 1,000, the decimal point shifts to the right by 1, 2, or 3 places. Similarly, when dividing a whole number by 10, 100, or 1,000, the decimal point shifts to the left.

#### **c. Demonstrate with examples that multiplication of a number by a decimal or a fraction may result in either a smaller or a larger number.**

**Note:** Decimals, like fractions, can be greater than one.

### **N.5.7 Understand the notation and calculation of positive whole number powers.**

#### **a. Recognize and use the definition and notation for exponents.**

- If  $p$  is a positive whole number, then  $a^p$  means  $a \times a \times a \times \dots \times a$  ( $p$  times).

**Note:** Emphasize two special cases: powers of 2 and powers of 10.

- Understand and use the language of exponents and powers.

**Note:** In the expression  $10^3$ , 3 is an exponent and  $10^3$  is a power of 10.



### **N.5.8 Solve multi-step problems using multi-digit positive numbers, fractions, and decimals.**

#### **a. Solve problems of various types--mathematical tasks, word problems, contextual questions, and real-world settings.**

**Note:** *As noted earlier, problem-solving is an implied part of all expectations. To focus on strategies for solving problems that are cognitively more complex than those previously encountered, computational demands should be kept simple.*

#### **b. Translate a problem's verbal statements or contextual details into diagrams, symbols, and numerical expressions.**

#### **c. Express answers in appropriate verbal or numerical form.**

- Provide units in answers.
- Use estimation to judge reasonableness of answers.
- Use calculators to check computations.
- Round off answers as needed to a reasonable number of decimal places.

#### **d. Solve problems that require a mixture of arithmetic operations, parentheses, and arithmetic laws (commutative, distributive, associative).**

#### **e. Use mental arithmetic with simple multiplication and division of whole numbers, fractions, and decimals.**

## **Grade 6**

### **N.6.1 Understand and use negative numbers.**

#### **a. Know the definition of a negative number and how to locate negative numbers on the number line.**

- If  $a$  is a positive number,  $-a$  is a number that satisfies  $a + (-a) = 0$ .
- On the number line,  $-a$  is the mirror image of  $a$  with respect to 0; it lies as far to the left of 0 as  $a$  lies to the right.

**Note:** *In elementary school, a negative number  $-a$  is sometimes called the "opposite" of  $a$ , but this terminology is not used in later grades.*

- Negative numbers may be either whole numbers or fractions.
- The positive whole numbers together with their negative counterparts and zero are called *integers*.

**Note:** *The properties of negative numbers apply equally to integers and to fractions. Thus it is just as effective (and certainly easier) to limit to integers all examples that introduce the behavior of negative numbers.*

**Note:** *The positive fractions together with the negative fractions and zero (which include all integers) are called rational numbers. In grade 6, these are all the numbers we have, so they are usually referred to just as "numbers." Later when irrational numbers are introduced, the distinction between rational and irrational will be important--but not now.*

**b. Understand why  $-(-a) = a$  for any number  $a$ , both when  $a$  is positive and when  $a$  is negative.**

- Use parentheses, as in  $-(-a)$ , to distinguish the subtraction operation (minus) from the negative symbol.

**c. Use the number line to demonstrate how to subtract a larger number from a smaller one.**

- If  $b > a$ , the point  $c$  on the number line that lies at distance  $b - a$  to the left of zero satisfies the relation  $a - b = c$ . Thus  $a - b = -(b - a)$ .
- Subtracting a smaller from a larger number is the same as adding the negative of the smaller number to the larger. That is, if  $a > b$  then  $a - b = a + (-b)$ .

**Note:** *Formally,  $a + (-b) = (a - b) + b + (-b) = (a - b) + 0 = a - b$ .*

- **Recognize that  $a + (-b) = a - b$  (even when  $b > a$ ).**

Example:  $3 - 8 = -5$  because  $5 + (3 - 8) = 5 + (3 + (-8)) = (5 + 3) + (-8) = 8 + (-8) = 0$ . Therefore,  $3 - 8$  satisfies the definition of  $-5$  as being that number which, when added to 5, yields zero.

**d. Recognize that all numbers, positive and negative, satisfy the same commutative, associative, and distributive laws.**

**Note:** *Demonstrations of these laws are part of Algebra, below. Here recognition and fluent use are the important issues.*

**N.6.2 Understand how to divide positive fractions and mixed numbers.**

**a. Understand that division of fractions has the same meaning as does division of whole numbers.**

- Just as  $A/B = C$  means that  $A = C \times B$  for whole numbers, so  $(a/b) / (c/d) = M/N$  means that  $(a/b) = (M/N) \times (c/d)$ .

**b. Use and be able to explain the "invert and multiply" rule for division of fractions.**

- Invert and multiply means:  $(a/b)/(c/d) = (a/b) \times (d/c) = (ad)/(bc)$ .

**Note:** *To verify that  $(a/b)/(c/d) = (ad)/(bc)$ , we need to check that  $(ad)/(bc)$  satisfies the definition of  $(a/b)/(c/d)$ , namely, that  $(a/b) = (ad)/(bc) \times (c/d)$ :  
 $(ad)/(bc) \times (c/d) = (a/b) \times (d/c) \times (c/d) = (a/b) \times 1 = a/b$ .*

**c. Find unknowns in division and multiplication problems using both whole and mixed numbers.**

- Solve problems of the form  $a \div [ ] = b$ ,  $a \times [ ] = b$ ,  $[ ] \div a = b$ .

Examples:  $\frac{1}{4} \div [ ] = 1$ ;  $\frac{1}{4} \div [ ] = \frac{3}{4}$ ;  $\frac{1}{2} = 1 \times [ ]$ ;  $2\frac{1}{3} \div 1\frac{1}{2} = [ ]$ ;  $2\frac{1}{3} \div [ ] = 1\frac{1}{2}$ .

**d. Create and solve contextual problems that lead naturally to division of fractions.**

- Recognize that division by a unit fraction  $\frac{1}{n}$  is the same as multiplying by its denominator  $n$ .

**N.6.3 Understand and use ratios and percentages.**

**a. Understand ratio as a fraction used to compare two quantities by division.**

- Recognize  $a:b$  and  $a/b$  as alternative notations for ratios.

**Note:** A ratio is often thought of as a pair of numbers rather than as a single number. Two such pairs of numbers represent the same ratio if one is a non-zero multiple of the other or, equivalently, if when interpreted as fractions, they are equivalent.

Example: 2:4 is the same ratio as 6:12, 8:16, or 1:2.

- Understand that quantities  $a$  and  $b$  can be compared using either subtraction ( $a - b$ ) or division ( $\frac{a}{b}$ ).
- Recognize that the terms *numerator* and *denominator* apply to ratios just as they do to fractions.

**b. Understand that percentage is a standardized ratio with denominator 100.**

- **Recognize common percentages and ratios based on fractions whose denominators are 2, 3, 4, 5, or 10.**

Examples: 20%, 25%,  $33\frac{1}{3}\%$ , 40%, 50%,  $66\frac{2}{3}\%$ , 90%, and 100% and their ratio, fraction, and decimal equivalents.

- Express the ratio between two quantities as a percent and a percent as a ratio or fraction.

**c. Create and solve word problems involving ratio and percentage.**

- Write number sentences and contextual problems involving ratio and percentage.

**N.6.4 Understand and use exponents and scientific notation.**

**a. Calculate with integers using the law of exponents:  $b^n \times b^m = b^{n+m}$ .**

- Just as  $b \times n$  (with  $b$  and  $n$  positive) can be understood as  $b$  added to itself  $n$  times, so  $b^n$  can be understood as  $b$  multiplied by itself  $n$  times.

**Note:** *The law of exponents for positive exponents is just a restatement of this definition, since both  $b^n \times b^m$  and  $b^{n+m}$  mean  $b$  multiplied by itself  $n + m$  times.*

**Note:** *If  $b > 0$ ,  $b^1 = b$ ,  $b^0 = 1$ . The same is true of  $b < 0$ . If  $b = 0$ ,  $0^1 = 0$ , but  $0^0$  is not defined.*

- If  $n > 0$ ,  $b^{-n}$  means  $1/b^n$  (that is, 1 divided by  $b$   $n$  times).

**Note:** *This definition of  $b^{-n}$  is designed to make the law of exponents work for all integers (positive or negative):  $b^n \times b^{-n}$  means  $b$  multiplied by itself  $n$  times, then divided by  $b$   $n$  times, yielding 1. Thus  $b^n \times b^{-n} = b^{n+(-n)} = b^0 = 1$ .*

Example:  $3^{-2} = (\frac{1}{3})^2 = \frac{1}{9}$ ;  $3^3 = 27$ ;  $3^3 \times 3^{-2} = 3^{(3-2)} = 3^1 = 3 = 27 \times \frac{1}{9} = \frac{27}{9}$ .

**b. Understand scientific notation and use it to express numbers and to compute products and quotients.**

- Recognize the importance of scientific notation to express very large and very small numbers.
- Locate very large and very small numbers on the number line.
- Understand the concept of *significant digit* and the role of scientific notation in expressing both magnitude and degree of accuracy.

**c. Model exponential behavior with contextual illustrations based on population growth and compound interest.**

**N.6.5 Solve multi-step mathematical, contextual, and verbal problems using rational numbers.**

**a. Solve arithmetic problems involving more than one arithmetic operation using rational numbers.**

- Calculate with and solve problems involving negative numbers, percentages, ratios, exponents, and scientific notation.

**Note:** *As usual, keep calculations simple in order to focus on the new concepts.*

- Compare numbers expressed in different ways and locate them on the number line.
- Write number sentences involving negative numbers, percentages, ratios, exponents, and scientific notation.

**b. Solve relevant contextual problems (e.g., sports, discounts, sales tax, simple and compound interest).**

- Represent problems mathematically using diagrams, numbers, and symbolic expressions.
- Express answers clearly in verbal, numerical, symbolic, or graphical form.
- Use estimation to check answers for reasonableness and calculators to check for accuracy.

- Describe real situations that require understanding of and calculation with negative numbers, percentages, ratios, exponents, and scientific notation.

## Measurement (M)

### Kindergarten

#### **M.K.1 Compare the length, weight, and capacity (volume) of objects.**

**a. Make direct comparisons between objects (e.g., recognize which is shorter, longer, taller, lighter, heavier, or holds more).**

**b. Estimate length, weight, and capacity, and check estimates with actual measurements.**

- Select and use appropriate measurement tools (rulers, tape measures, scales, containers, clocks, thermometers).
- Relate direct comparisons of objects to comparisons of numerical measurements or estimates.

Example: Tom, who is four feet tall, is shorter than Jose, who is five feet tall, because 4 is smaller than 5.

### Grade 1

#### **M.1.1 Measure length, weight, capacity, time, and money.**

**a. Use rulers, scales, and containers to measure and compare the dimensions, weight, and capacity (volume) of classroom objects.**

***Note:** The concepts of addition and order are intrinsic in quantities such as length, weight, and volume (capacity). So measuring such quantities provides an independent empirical basis for understanding the properties of numbers that is different from simple counting.*

- Round off measurements to whole numbers.
- Recognize the essential role of units in measurement and understand the difference between *standard* and *non-standard* units.

*Example:* An inch or foot marked on a ruler is a standard unit, whereas a paperclip or a classmate's foot used to measure is a non-standard unit.

- Represent addition by laying rods of different lengths end to end, combining items on a balance, and pouring liquids or sand into different containers.
- Estimate lengths with simple approximations.
- Understand and use comparative words such as *long, longer, longest; short, shorter, shortest; tall, taller, tallest; high, higher, highest*.

**b. Tell time from analog (round) clocks in half-hour intervals.**

- Use the expressions "o'clock" and "half past."

**c. Count, speak, write, add, and subtract amounts of money in cents up to \$1 and in dollars up to \$10.**

- Know the values of U.S. coins (penny, nickel, dime, quarter, dollar bill).
- Use the symbols \$ and ¢ separately (e.g., \$4, 35¢ instead of \$PS.4.35).
- Use coins to decompose monetary amounts given in cents.

*Example:*  $17¢ =$  one dime, one nickel, and two pennies  $= 10 + 5 + 1 + 1$ ; or  $17¢ =$  three nickels and two pennies  $= 5 + 5 + 5 + 1 + 1$ .

- Understand and solve money problems expressed in a different ways, including *how much more* or *how much less*.

**Note:** *Avoid problems that require conversion from cents to dollars or vice versa.*

## Grade 2

### M.2.1 Add, subtract, compare, and estimate measurements.

**a. Estimate, measure, and calculate length in meters, centimeters, yards, feet, and inches.**

- Recognize and use standard abbreviations: m, cm, yd, ft, and in, as well as the symbolic notation 3'6".
- Understand and use units appropriate to particular situations.  
*Example: Standard U.S. school notepaper is sized in inches, not centimeters.*
- Add and subtract mixed metric units (e.g., 8m,10cm + 3m,5cm) but defer calculation with mixed English units (e.g., 3ft,1in + 1ft,8in) until third grade.

**Note:** *Conversion between systems awaits a later grade.*

**b. Measure the lengths of sides and diagonals of common two-dimensional figures such as triangles, rectangles (including squares), and other polygons.**

- Measure to the nearest centimeter or half inch using meter sticks, yardsticks, rulers, and tape measures marked in either metric or English units.

**Note:** *Measure within either system without conversion between systems.*

- Create and use hand-made rulers by selecting an unconventional unit length (e.g., a hand-width), marking off unit and half-unit lengths.
- Explore a variety of ways to measure perimeter and circumference.

**Examples:** Encircle with a tape measure; measure and sum various pieces; wrap with a string and then measure the length of the string. Compare answers obtained by different strategies and explain any differences.

**Note:** *Comparing the result of a direct measurement (encircling) with that of adding component pieces underscores the importance of accuracy and serves as a prelude to understanding the significance of significant digits.*

**c. Estimate and measure weight and capacity in common English and metric units.**

- Recognize, use, and estimate common measures of volume (quarts, liters, cups, gallons) and weight (pound, kilogram).
- Understand and use common expressions such as *half a cup* or *quarter of a pound* that represent fractional parts of standard units of measurement.

**d. Compare lengths, weights, and capacities of *pairs* of objects.**

- Demonstrate that the combined length of the shorter pieces from two pairs of rods is shorter than the combined lengths of the two longer pieces.
- Recognize that the same applies to combined pairs of weights or volumes.

**Note:** *Even though this relation may seem obvious, it is an important demonstration of the fundamental relation between addition and order, namely, that if  $a \leq b$  and  $c \leq d$ , then  $a + c \leq b + d$ .*

### Grade 3

**M.3.1 Recognize why measurements need units and know how to use common units.**

**a. Understand that all measurements require units and that a quantity accompanied by a unit represents a measurement.**

- Know and use the names and approximate magnitudes of common units:
  - For length: kilometer, meter, centimeter; mile, yard, foot, inch.
  - For capacity: liter, milliliter; gallon, quart, pint, cup.
  - For time: year, month, week, day, hour, minute, second
  - For money: pennies, nickels, dimes, quarters, dollars.

**Note:** *Many of these units have been introduced in prior grades; others will be introduced in later grades. Here some are pulled together for reinforcement and systematic use. Each year in grades 2–6 some new measures should be introduced and previous ones reinforced. Which are done in which grades is of lesser importance.*

**b. Know common within-system equivalences:**

- 1 meter = 100 centimeters, 1 yard = 3 feet, 1 foot = 12 inches.
- 1 liter = 1,000 milliliters, 1 gallon = 4 quarts, 1 quart = two pints.
- 1 year = 12 months, 1 week = 7 days, 1 hour = 60 minutes, 1 minute = 60 seconds.
- 1 dollar = 4 quarters = 10 dimes = 100 pennies, 1 quarter = 5 nickels = 25 pennies, 1 dime = 2 nickels = 10 pennies, 1 nickel = 5 pennies.



**c. Choose reasonable units of measure, estimate common measurements, use appropriate tools to make measurements, and record measurements accurately and systematically.**

- Make and record measurements that use mixed units within the same system of measurement (e.g., feet and inches, hours and minutes).

**Note:** *Many situations admit various approaches to measurement. Using different means and comparing results is a valuable activity.*

- Understand that errors are an intrinsic part of measurement.
- Understand and use time both as an absolute (12:30 p.m.) and as duration of a time interval (20 minutes).
- Understand and use idiomatic expressions of time (e.g., "10 minutes past 5," "quarter to 12," "one hour and ten minutes").

**d. Use decimal notation to express, add, and subtract amounts of money.**

**Note:** *Dealing with money enables students to become accustomed to decimal notation, i.e.,  $\$1.49 + \$0.25 = \$1.74$ .*

**e. Solve problems requiring the addition and subtraction of lengths, weights, capacities, times, and money.**

- Include use of common abbreviations: m, cm, kg, g, l, ml, hr, min, sec, in, ft, lb, oz, \$, ¢.

**Note:** *Add and subtract only within a single system, using quantities within students' experience. Use real data where possible, but limit the size and complexity of numbers so that problem solving, not computation, is the central challenge of each task.*

## Grade 4

### **M.4.1 Understand and use standard measures of length, area, and volume.**

**a. Know and use common units of measure of length, area and volume in both metric and English systems.**

- Always use units when recording measurements.
- Know both metric and English units: centimeter, square centimeter, cubic centimeter; meter, square meter, cubic meter; inch, square inch, cubic inch; foot, square foot, cubic foot.
- Use abbreviations: m, cm, in, ft, yd;  $m^2$ ,  $cm^2$ ,  $in^2$ ,  $ft^2$ ,  $yd^2$ ; sq m, sq cm, sq in, sq ft, sq yd;  $m^3$ ,  $cm^3$ ,  $in^3$ ,  $ft^3$  and  $yd^3$ .

**b. Convert measurements of length, weight, area, volume, and time within a single system.**

**Note:** *Emphasize conversions that are common in daily life. Common conversions typically involve adjacent units—for example, hours and minutes or minutes and seconds, but not hours and seconds. Know common within-system equivalences.*

- Use unit cubes to build solids of given dimensions and find their volumes.
- 1 square foot =  $12^2$  square inches; 1 square meter as  $100^2$  square centimeters; 1 cubic foot =  $12^3$  cubic inches; 1 cubic meter as  $100^3$  cubic centimeters.

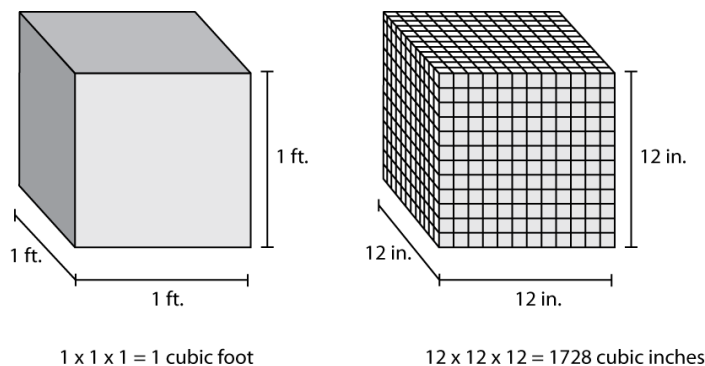

**c. Visualize, describe, and draw the relative sizes of length, area, and volume units in the different measurement systems.**

- Estimate areas of rectangles in square inches and square centimeters.

**Note:** *Avoid between-system conversions.*

Examples: Centimeter vs. inch, foot and yard vs. meter; square centimeter vs. square inch; square yard vs. square meter; cubic foot vs. cubic meter.

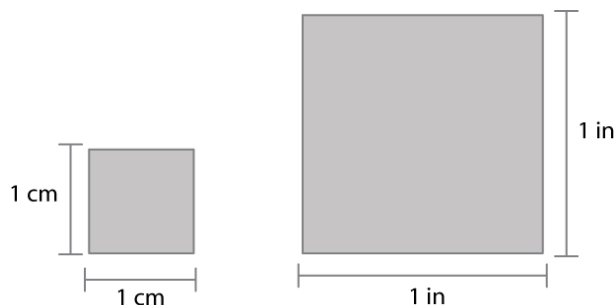

**d. Recognize that measurements are never exact.**

- Both recorded data and answers to calculations should be rounded to a degree of precision that is reasonable in the context of a given problem and the accuracy of the measuring instrument.

**Note:** *All measurements of continuous phenomena such as length, capacity, or temperature are approximations. Measurements of discrete items such as people or bytes can be either exact (e.g., size of an athletic team) or approximate (e.g., size of a city).*

**e. Solve problems involving area, perimeter, surface area or volume of rectangular figures.**

- Select appropriate units to make measurements of everyday objects, record measurements to a reasonable degree of accuracy, and use a calculator when appropriate to compute answers.
- Know that answers to measurement problems require appropriate units in order to have any meaning.

**Note:** *Include figures whose dimensions are given as fractions or mixed numbers.*

## Grade 5

### **M.5.1 Make, record, display, and interpret measurements of everyday objects.**

#### **a. Select appropriate units to make measurements and include units in answers.**

#### **b. Recognize and use measures of weight, information, and temperature.**

- For information: bytes, kilobytes (K or Kb), megabytes (M), gigabytes (G).  $1\text{G} = 1,000\text{M}$ ,  $1\text{M} = 1,000\text{K}$ ,  $1\text{K} = 1,000$  bytes.

**Note:** *Literally, the multiplier is  $1,024 = 2^{10}$ , but for simplicity in calculation, 1,000 is generally used instead.*

- For weight: kilogram (kg), gram (g), pound (lb), ounce (oz).  $1\text{kg} = 1000\text{g}$ ,  $1\text{lb} = 16\text{oz}$ .
- For temperature: Centigrade and Fahrenheit degrees.  $32^{\circ}\text{F} = 0^{\circ}\text{C}$ ;  $212^{\circ}\text{F} = 100^{\circ}\text{C}$ .

#### **c. Record measurements to a reasonable degree of accuracy, using fractions and decimals as needed to achieve the desired detail.**

#### **d. When needed, use a calculator to find answers to questions associated with measurements.**

- Understand the role of significant digits in signaling the accuracy of measurements and associated calculations.

*Example:* Report a city's population as 210,000, not as 211,513.

#### **e. Create graphs and tables to present and communicate data.**

## Grade 6

**Note:** *Measurement is not a focus in grade 6 of these expectations.*

## Probability and Statistics (PS)

### Kindergarten

#### **PS.K.1 Recognize and use words that represent time, temperature, and money.**

- a. Recognize and use the words day, night, morning, afternoon, evening, yesterday, today, tomorrow.**
  - Identify daily landmark times such as *bedtime* or *lunch time*.
- b. Recognize the role of clocks and calendars in measuring and keeping track of time.**
- c. Know that thermometers measure temperature and that *degree* is the word used to name a temperature.**
- d. Identify U.S. coins by name.**

### Grade 1

#### **PS.1.1 Use picture graphs to pose and solve problems.**

- a. Interpret picture graphs in words (orally) and with numbers.**
  - Answer questions about the meaning of picture graphs.
- b. Create picture graphs of counts and measurements from collected or provided data.**
  - Represent data both in horizontal and vertical forms.
  - Label axes or explain what they represent
  - Pose and answer comparison questions based on picture graphs.

### Grade 2

#### **PS.2.1 Tell, estimate, and calculate with time.**

- a. Tell, write, and use time measurements from analog (round) clock faces and from digital clocks and translate between the two.**
  - Round off to the nearest five minutes.
  - Understand and use different ways to read time, e.g., "nine fifteen" or "quarter past nine," "nine fifty" or "ten to ten."
  - Understand a.m. and p.m.

**b. Understand the meaning of time as an interval and be able to estimate the passage of time without clock measurement.**

**c. Understand and use comparative phrases such as "in fifteen minutes," "half an hour from now," "ten minutes late."**

**PS.2.2 Count, add, and subtract money.**

**a. Read, write, add, and subtract money up to 10 dollars.**

- Handle money accurately and make change for amounts of \$10 or less by counting up.
- Use the symbols \$ and ¢ properly
- Recognize and use conventional ("decimal") monetary notation and translate back and forth into \$ and ¢ notation.
- Add and subtract monetary amounts in both \$ and ¢ and conventional notation.
- Use a calculator to check monetary calculations and also to add lists of three or more amounts.
- Estimate answers to check for reasonableness of hand or calculator methods.

**PS.2.3 Represent measurements by means of bar graphs.**

**a. Collect data and record them in systematic form.**

**b. Select appropriate scales for a graph and make them explicit in labels.**

- Employ both horizontal and vertical configurations.
- Recognize an axis with a scale as a representation of the number line.
- Compare scales on different graphs.
- Use addition and subtraction as appropriate to translate data (gathered or provided) into measurements required to construct a graph.

**c. Create and solve problems that require interpretation of bar or picture graphs.**

**Grade 3**

***Note:** Probability and Statistics is not a focus in grade 3 of these expectations.*

## Grade 4

### **PS.4.1 Record, arrange, present, and interpret data using tables and various types of graphs.**

#### **a. Create and interpret line, bar, and circle graphs and their associated tables of data.**

- Create and label appropriate scales for graphs.
- Prepare labels or captions to explain what a table or graph represents.
- Solve problems using data presented in graphs and tables.
- Employ fractions and mixed numbers, as needed, in tables and graphs.

## Grade 5

### **PS.5.1 Find, interpret, and use the average (mean) of a set of data.**

#### **a. Calculate the average of a set of data that includes whole numbers, fractions, and decimals.**

*Note: Emphasize that data is plural and datum is singular, the name for a single number in a set of data.*

- Infer characteristics of a data set given the mean and other incomplete information.

## Grade 6

### **PS.6.1 Understand the meaning of probability and how it is expressed.**

#### **a. The probability of an event is a number between zero and one that expresses the likelihood of an occurrence.**

- The probability of an occurrence is the ratio of the number of actual occurrences to the number of possible occurrences.
- Understand different ways of expressing probabilities--as percentages, decimals, or odds.

*Example:* If the probability of rain is .6, the weather forecaster could say that there is a 60% chance of rain or that the odds of rain are 6:4 (or 3:2).

- If  $p$  is the probability that an event will occur, then  $1 - p$  is the probability that it will not occur.

*Example:* If the probability of rain is 60%, then the probability that it will not rain is  $100\% - 60\% = 40\%$ . (Equivalently,  $1 - .60 = .40$ .)

## Geometry (G)

### Kindergarten

#### **G.K.1 Create, explore, and describe shapes.**

##### **a. Identify common shapes such as rectangle, circle, triangle, and square.**

- Draw a variety of triangles (equilateral, right, isosceles, scalene) in a variety of positions.
- Draw squares and rectangles of different proportions (tall, squat, square-like) both horizontally and vertically positioned. Recognize tipped squares and rectangles.

**Note:** *Squares are a type of rectangle.*

**Note:** *Drawing of tipped rectangles is typically too hard for kindergarten.*

- Describe attributes of common shapes (e.g., number of sides and corners).

##### **b. Use geometric tiles and blocks to assemble compound shapes.**

- Assemble rectangles from two congruent right triangular tiles.
- Explore two-dimensional symmetry using matching tiles.

##### **c. Recognize and use words that describe spatial relationships such as *above, below, inside, outside, touching, next to, far apart.***

### Grade 1

#### **G.1.1 Recognize, describe, and draw geometric figures.**

##### **a. Identify and draw two-dimensional figures.**

- Include trapezoids, equilateral triangles, isosceles triangle, parallelograms, quadrilaterals.

**Note:** *Be sure to include a robust variety of triangles as examples, especially ones that are very clearly not equilateral or isosceles.*

- Describe attributes of two-dimensional shapes (e.g., number of sides and corners).

##### **b. Identify and name three-dimensional figures.**

- Include spheres, cones, prisms, pyramids, cubes, rectangular solids.
- Identify two-dimensional shapes as faces of three-dimensional figures.

##### **c. Sort geometric objects by shape and size.**

- Recognize the attributes that determined a particular sorting of objects and use them to extend the sorting.

*Example:* Various L-shaped figures constructed from cubes are sorted by the total number of cubes in each. Recognize this pattern, then sort additional figures to extend the pattern.

- Explore simultaneous independent attributes.

*Example:* Sort triangular tiles according to the four combinations of two attributes, such as right angle and equal sides.

### **G.1.2 Rotate, invert, and combine geometric tiles and solids.**

#### **a. Describe and draw shapes resulting from rotation and flips of simple two-dimensional figures.**

- Identify the same (congruent) two-dimensional shapes in various orientations and move one on top of the other to show that they are indeed identical.
- Extend sequences that show rotations of simple shapes.

#### **b. Identify symmetrical shapes created by rotation and reflection.**

#### **c. Use geometric tiles and cubes to assemble and disassemble compound figures.**

- Count characteristic attributes (lines, faces, edges) before and after assembly.

*Examples:* Add two right triangles to a trapezoid to make a rectangle; create a hexagon from six equilateral triangles; combine two pyramids to make a cube.

## **Grade 2**

### **G.2.1 Recognize, classify, and transform geometric figures in two and three dimensions.**

#### **a. Identify, describe, and compare common geometric shapes in two and three dimensions.**

- Define a general triangle and identify isosceles, equilateral, right, and obtuse special cases.

**Note:** *The goal of naming triangles is not the names themselves but to focus on important differences. Triangles (or quadrilaterals) are not all alike, and it is their differences that give them distinctive mathematical features.*

- Identify various quadrilaterals (rectangles, trapezoids, parallelograms, squares) as well as pentagons and hexagons.

**Note:** *In this grade parallel is used informally and intuitively; it receives more careful treatment at a later grade.*

**Note:** *A square is a special kind of rectangle (since it has four sides and four right angles); a rectangle is a special kind of parallelogram (since it has four sides and two pairs of parallel sides); and a parallelogram is a special kind of trapezoid (since it has*



*four sides and at least one pair of parallel sides); and a trapezoid is a polygon (since it is a figure formed of several straight sides). So for example, contrary to informal usage, in mathematics, a square is a trapezoid.*

- Understand the terms *perimeter* and *circumference*.

**Note:** *The primary meaning of both terms is the outer boundary of a two-dimensional figure; circumference is used principally in reference to circles. A secondary meaning for both is the length of the outer boundary. Which meaning is intended needs to be determined from context.*

- Distinguish circles from ovals; recognize the circumference, diameter, and radius of a circle.
- In three dimensions, identify spheres, cones, cylinders, and triangular and rectangular prisms.

**b. Describe common geometric attributes of familiar plane and solid objects.**

- Common geometric attributes include position, shape, size, and roundness and numbers of corners, edges, and faces.
- Distinguish between geometric attributes and other characteristics such as weight, color, or construction material.
- Distinguish between lines and curves and between flat and curved surfaces.

**c. Rotate, flip, and fold shapes to explore the effect of transformations.**

- Use paper folding to find lines of symmetry.
- Recognize congruent shapes.
- Identify shapes that have been moved (flipped, slid, rotated), enlarged, or reduced.

**G.2.2 Understand and interpret rectangular arrays as a model of multiplication.**

**a. Create square cells from segments of the discrete number line used as sides of a rectangle.**

- •Match cells to discrete objects lined up in regular rows of the same length.

**b. Understand rectangular arrays as instances of repeated addition.**

**Grade 3**

**G.3.1 Recognize basic elements of geometric figures and use them to describe shapes.**

**a. Identify points, rays, line segments, lines, and planes in both mathematical and everyday settings.**

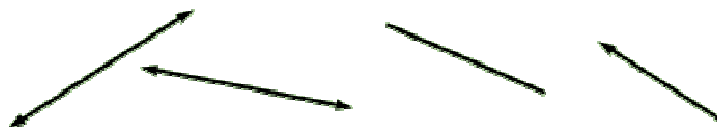

- A *line* is a straight path traced by a moving point having no breadth nor end in either direction.

**Examples:** Each figure on the left above represents a line; the arrows indicate that the lines keep going in the indicated directions without end. The number line with both positive and negative numbers is a line.

- A part of a line that starts at one point and ends at another is called a *line segment*. Line segments are drawn without arrows on either end because line segments end at points.

**Examples:** The figure in the center above is a line segment. The edges of a desk or door or piece of paper are everyday examples of line segments.

- Part of a line that starts at one point and goes on forever in one direction is called a *ray*.

**Examples:** The figure at the top right below is a ray. The positive number line (to the right of 0) is a ray. On the other hand, none of the four examples below are lines:

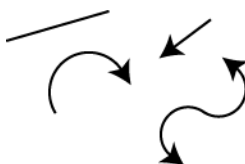

**Caution:** *Not all sources distinguish carefully among the terms line, segment or ray, nor do all sources employ the convention of arrowheads in exactly the manner described above. Often context is the best guide to distinguish among these terms.*

- Know that a *plane* is a flat surface without thickness that extends indefinitely in every direction.

**Examples:** Everyday examples that illustrate a part of a plane are the flat surfaces of a floor, desk, windowpane, or book. Examples that are not part of a plane are the curved surfaces of a light bulb, a ball, or a tree.

**b. Understand the meaning of parallel and perpendicular and use these terms to describe geometric figures.**

- Lines and planes are called *parallel* if they do not meet no matter how far they are extended.
- Lines and planes are called *perpendicular* if the corners formed when they meet are equal.
- Identify parallel and perpendicular edges and surfaces in everyday settings (e.g., the classroom).

**Examples:** The lines on the page of a notebook are parallel, as are the covers of a closed book. Corners of books, walls, and rectangular desks are perpendicular, as are the top and side edges of a chalk board and a wall and a floor in a classroom.

- The corner where two perpendicular lines meet is called a *right angle*.

**Note:** *The general concept of "angle" is developed later; here the term is used merely as the name for this specific and common configuration.*

- Understand and use the terms *vertical* and *horizontal*.
- Recognize that vertical and horizontal lines or planes are perpendicular, but that perpendicular lines or planes are not necessarily vertical or horizontal.

**c. Use terms such as line, plane, ray, line segment, parallel, perpendicular, and right angle correctly to describe everyday and geometric figures.**

**G.3.2 Identify and draw perpendicular and parallel lines and planes.**

**a. Draw perpendicular, parallel, and non-parallel line segments using rulers and squares.**

- Recognize that lines that are parallel to perpendicular lines will themselves be perpendicular.

*Example:* Fold a piece of paper in half from top to bottom, then fold it in half again from left to right. This will give two perpendicular fold lines and four right angles.

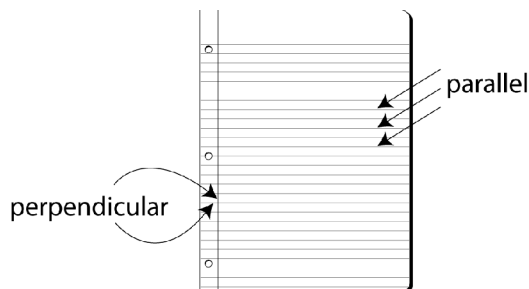

- Edges of a polygon are called parallel or perpendicular if they lie on parallel or perpendicular lines, respectively.
- Similarly, faces of a three-dimensional solid are called parallel or perpendicular if they lie in parallel or perpendicular planes, respectively.

**G.3.3 Explore and identify familiar two- and three-dimensional shapes.**

**a. Describe and classify plane figures and solid shapes according to the number and shape of faces, edges, and vertices.**

- Plane figures include circles, triangles, squares, rectangles, and other polygons; solid shapes include spheres, pyramids, cubes, and rectangular prisms.

- Recognize that the exact meaning of many geometric terms (e.g., rectangle, square, circle and triangle) depends on context: Sometimes they refer to the boundary of a region and sometimes to the region contained within the boundary.

**b. Know how to put shapes together and take them apart to form other shapes.**

**Examples:** Two identical right triangles can be arranged to form a rectangle. Two identical cubes can be arranged to form a rectangular prism.

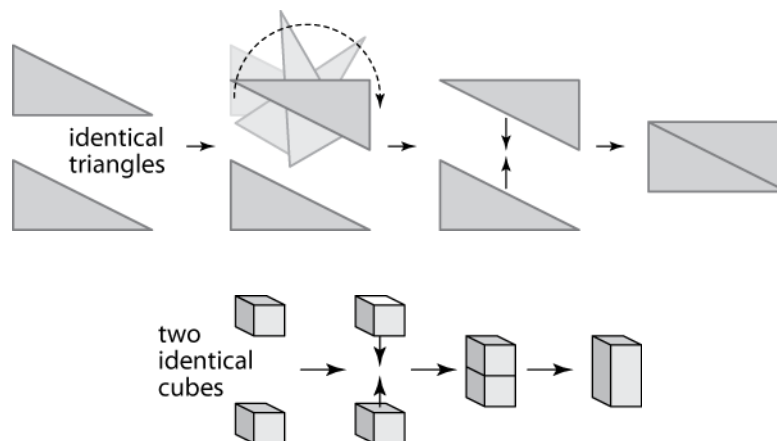

**c. Identify edges, vertices (corners), perpendicular and parallel edges and right angles in two-dimensional shapes.**

**Example:** A rectangle has four pairs of perpendicular edges, two pairs of parallel edges and four right angles.

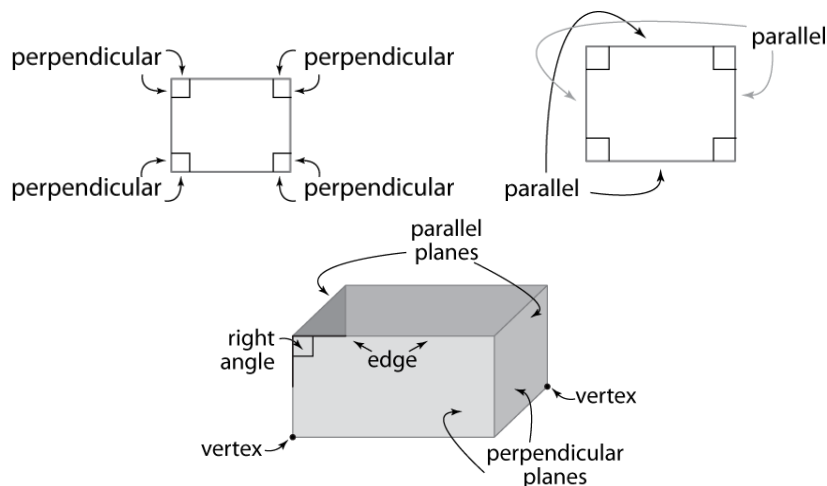

**d. Identify right angles, edges, vertices, perpendicular and parallel planes in three-dimensional shapes.**

**G.3.4 Understand how to measure length, area, and volume.**

**a. Understand that measurements of length, area, and volume are based on standard units.**

- Fundamental units are: a *unit interval* of length 1 unit, a *unit square* whose sides have length 1 unit, and a *unit cube* whose sides have length 1 unit.

- The *volume* of a rectangular prism is the number of unit cubes required to fill it exactly (with no space left over).

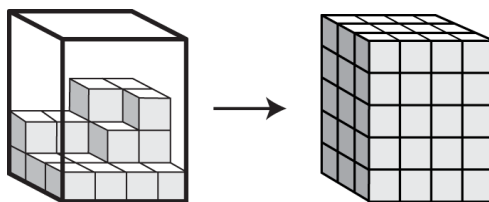

**Note:** *The common childhood experience of pouring water or sand offers a direct representation of volume.*

- The *area* of a rectangle is the number of unit squares required to pave the rectangle—that is, to cover it completely without any overlapping.

**Note:** *Area provides a critical venue for developing the conceptual underpinnings of multiplication.*

- The *length* of a line segment is the number of unit intervals that are required to cover the segment exactly with nothing left over.

**b. Know how to calculate the perimeter, area, and volume of shapes made from rectangles and rectangular prisms.**

- The *perimeter* of a rectangle is the number of unit intervals that are required to enclose the rectangle.
- Measure and compare the areas of shapes using non-standard units (e.g., pieces in a set of pattern blocks).
- Recognize that the area of a rectangle is the product of the lengths of its base and height ( $A = b \times h$ ) and that the volume of a rectangular prism is the product of the lengths of its base, width, and height ( $V = b \times w \times h$ ).

*Example:* Build solids with unit cubes and use the formula for volume ( $V = bwh$ ) to verify the count of unit cubes; make similar comparisons with rectilinear figures in the plane that are created from unit squares.

- Find the area of a complex figure by adding and subtracting areas.
- Compare rectangles of equal area and different perimeter and also rectangles of equal perimeter and different area.
- Measure surface area of solids by covering each face with copies of a unit square and then counting the total number of units.

## Grade 4

### G.4.1 Understand and use the definitions of angle, polygon, and circle.

**a. An angle in a plane is a region between two rays that have a common starting point.**

**Note:** According to this definition, a right angle (as determined by perpendicular rays) is indeed an angle.

**b. If angle A is contained in another angle B, then angle B is said to be bigger than angle A.**

- The figures below illustrate how to determine whether an angle is larger than, smaller than, or close to a right angle.

The angle is not contained in a right angle, so this tells us that it is larger than a right angle.

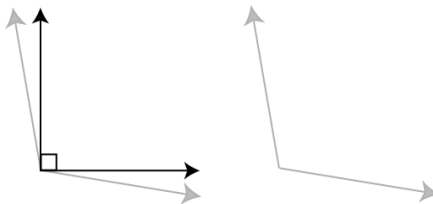

The angle is contained in a right angle, so this tells us that it is smaller than a right angle.

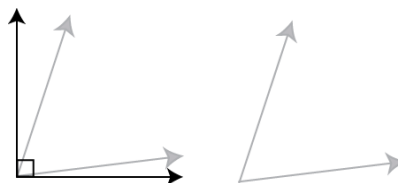

**Note:** When two rays come from the same point (see figure at right), they divide the plane into two regions, giving two angles. Except where otherwise indicated, the angle determined by the two rays is defined, by convention, as the smaller region.

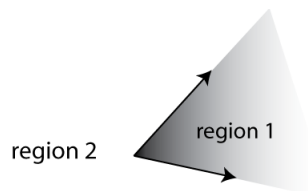

- Understand that shapes such as triangles, squares, and rectangles have angles.

**Note:** Technically, polygons do not contain rays, which are required for the definition of angles. Their sides are line segments of finite length. Nonetheless, if we imagine the sides extending indefinitely away from each corner, then each corner becomes an angle.

*Example:* Describe the difference between the two figures below.

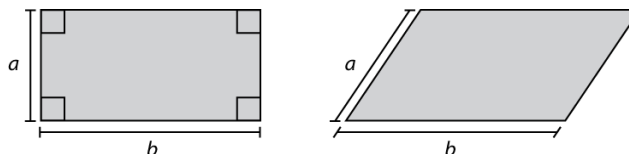

- Identify *acute*, *obtuse*, and *right* angles.

**c. Know and use the basic properties of squares; rectangles; and isosceles, equilateral and right triangles.**

- Identify *scalene*, *acute*, and *obtuse* triangles.
- Know how to mark squares, rectangles, and triangles appropriately.

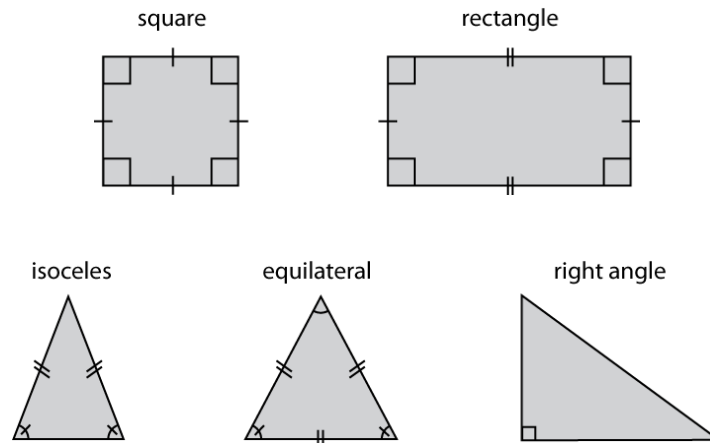

**d. Know what a polygon is and be able to identify and draw some examples.**

- A *polygon* is a figure that lies in a plane consisting of a finite number of line segments called *edges* (or *sides*) with the properties that (a) each edge is joined to exactly two other edges at the end points; edges do not meet each other except at end points; and the edges enclose a single region.

*Example:* The figures below are *not* polygons.

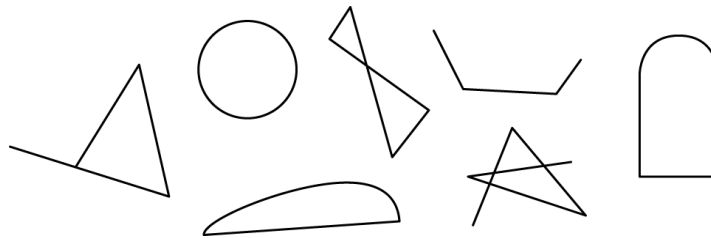

**e. Know and use the basic properties of a circle.**

- A circle is the set of points in a plane that are at a fixed distance from a given point.

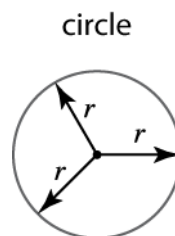

- Know that a circle is not a polygon.

## Grade 5

### G.5.1 Measure angles in degrees and solve related problems.

#### a. Understand the definition of *degree* and be able to measure angles in degrees.

- A *degree* is one part of the circumference of a circle of radius 1 unit (a *unit circle*) that is divided into 360 equal parts. The measure of an angle in degrees is defined to be the number of degrees of the arc of the unit circle, centered at the vertex of the angle, that is intercepted by the angle.
- The measure of an angle in degrees can also be interpreted as the amount of counter-clockwise turning from one ray to the other.

**Note:** *Earlier (in grade 4), the angle determined by two rays was defined to be smaller of the two options. For consistency, therefore, when an angle is measured by the amount of turning necessary to rotate one ray into another, it is important to start with the particular ray that will produce an angle measure no greater than  $180^\circ$ .*

- The symbol  $^\circ$  is an abbreviation for "degree" (e.g., 45 degrees =  $45^\circ$ ).
- As a shorthand, angles are called equal if the measures of the angles are equal.

#### b. Know and use the measures of common angles.

- Recognize that angles on a straight line add up to  $180^\circ$  and that angles around a point add up to  $360^\circ$ . An angle of  $180^\circ$  is called a *straight angle*.
- A right angle is an angle of  $90^\circ$ . An acute angle is an angle of less than  $90^\circ$ , while an obtuse angle is an angle of more than  $90^\circ$ .

**Note:** *Since a pair of perpendicular lines divides the plane into 4 equal angles, the measure of a right angle is  $360^\circ/4 = 90^\circ$ .*

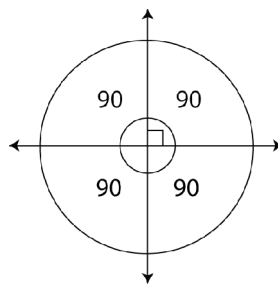

#### c. Interpret and prepare circle graphs (pie charts).

### G.5.2 Know how to do basic constructions using a straightedge and compass.

- #### a. Basic constructions include (a) drop a perpendicular from a point to a line, (b) bisect an angle, (c) erect the perpendicular bisector of a line, and (d) construct a hexagon on a circle.



**Note:** A straightedge is a physical representation of a line, not a ruler that is used for measuring. The role of a straightedge in constructions is to draw lines through two points, just as the role of the compass is to draw a circle based on two points, the center and a point on the circumference.

**Note:** Students need extended practice with constructions, since constructions embody the elements of geometry--lines and circles--independent of numbers and measurement. Since constructions are so central to Euclidean geometry, they are often called Euclidean constructions.

**Note:** These constructions are basic in the sense that other important constructions introduced in later grades (e.g., of an equilateral triangle given one side; of a square inscribed in a circle) build on them.

- Use informal arguments such as paper folding to verify the correctness of constructions.

### G.5.3 Recognize and work with simple polyhedra.

#### a. Represent and work with rectangular prisms by means of orthogonal views, projective views, and nets.

- A net is a flat (two-dimensional) pattern of faces that can be folded to form the surface of a solid.

**Note:** Because a net represents the surface of a polyhedra spread out in two dimensions, the area of a net equals the surface area of the corresponding solid.

- Orthogonal views are from top, front, and side; picture views are either projective or isometric; and nets are plane figures that can be folded to form the surface of the solid.

**Example:** An orthogonal view (a), a projective view (b), and a net (c) of the same rectangular prism:

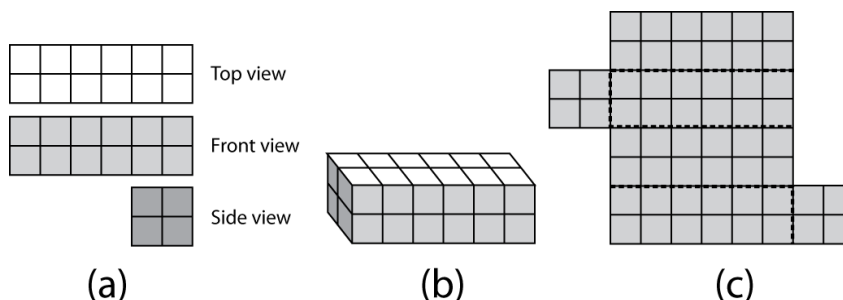

#### b. Recognize the five regular ("Platonic") solids.

- Count faces, edges, and vertices, and make a table with the results.

### G.5.4 Find the area of shapes created out of triangles.

#### a. Understand, derive, and use the formula $A = \frac{1}{2}bh$ for the area of a triangle.

- Arrange two identical right triangles with base  $b$  and height  $h$  to form a rectangle whose area is  $bh$ . Since the area of each right triangle is half that of the rectangle,  $A = \frac{1}{2}bh$ .

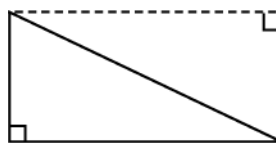

- If triangle  $ABC$  is not a right triangle, then placing two copies together will form a parallelogram with base  $b$  and height  $h$ . This parallelogram can be transformed into a rectangle of area  $bh$  by moving a right triangle of height  $h$  from one side of the parallelogram to the other. So here too,  $A = \frac{1}{2}bh$ .

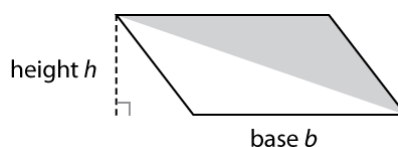

- Alternatively, to divide a general triangle  $ABC$  into two right triangles as shown below and combine the areas of the two parts:

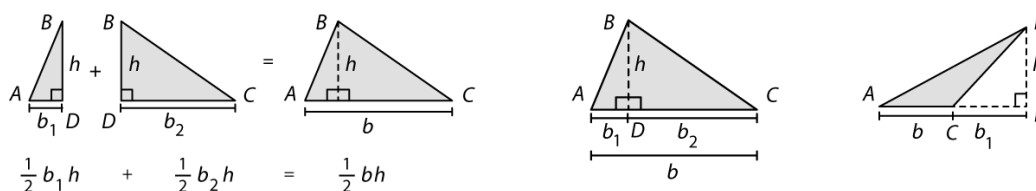

**Note:** As the diagrams show, there are two cases to consider: For an acute triangle (where all angles are smaller than a right angle), the parts are added together. For an obtuse triangle (where one angle is larger than a right angle), one right triangle must be subtracted from the other.

**b. Find the area of a convex polygon by decomposing it into triangles.**

- A polygon is called *convex* if a line segment joining any two points on the perimeter of the polygon will lie inside or on the polygon.
- Any convex polygon of  $n$  sides can be decomposed into  $(n - 2)$  triangles.

**c. Find the area of other geometric figures that can be paved by triangles.**

**G.5.5 Interpret and plot points on the coordinate plane.**

**a. Associate an ordered pair of numbers with a point in the first (upper right) quadrant and, conversely, any such point with an ordered pair of numbers.**

- Positions on the coordinate plane are determined in relation to the coordinate axes, a pair of number lines that are placed perpendicular to each other so that the zero point of each coincides.

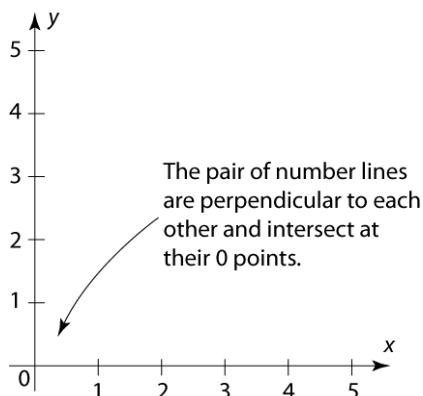

**Note:** The coordinate plane is a two-dimensional extension of the number line and builds on extensive (but separate) prior work with the number line and with perpendicular lines.

- Recognize the similarity between locating points on the coordinate plane and locating positions on a map.
- Recognize and use the terms *vertical* and *horizontal*.

**b. Identify characteristics of the set of points that define vertical and horizontal line segments.**

- Use subtraction of whole numbers, fractions, and decimals to find the length of vertical or horizontal line segments identified by the ordered pairs of its endpoints.

*Example:* What is the length of the line segment determined by  $(\frac{3}{5}, 0)$  and  $(1.5, 0)$ ?

**Grade 6**

**G.6.1 Understand and use basic properties of triangles and quadrilaterals.**

**a. Understand and use the angle properties of triangles and quadrilaterals.**

- The sum of angles in a right triangle is  $180^\circ$ , since two identical right triangles form a rectangle

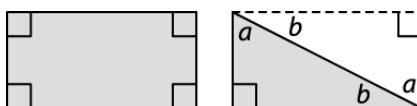

**Note:** By definition, a rectangle has 4 right angles, so the sum of the angles of a rectangle is  $4 \times 90^\circ = 360^\circ$ . Each right triangle contains half  $360^\circ$ , or  $180^\circ$ .

**Note:** Since one angle in a right triangle is  $90^\circ$ , the sum of the remaining two angles is also  $90^\circ$ .

- Since the sum of angles in a parallelogram is also  $360^\circ$ , the sum of angles in any triangle is also  $360^\circ/2 = 180^\circ$ .

**Note:** Following the line of argument used in grade 5 to find the area of a triangle, we note that (a) two identical copies of any triangle can be arranged to form a

parallelogram, and (b) any parallelogram can be transformed into a rectangle with the same angle sum by moving a triangle from one side of the parallelogram to the other.

**Note:** Alternatively, following the secondary argument offered in grade 5, one can drop a perpendicular to divide any triangle into two right triangles. The sum of the interior angles of each of these right triangles is  $180^\circ$ , but when put together they include two superfluous right angles. Subtracting these yields  $180^\circ + 180^\circ - (90^\circ + 90^\circ) = 180^\circ$  as the sum of the interior angles of any triangle.

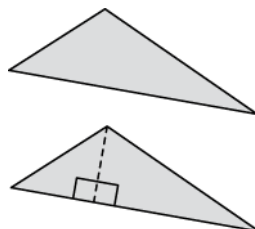

- Since any quadrilateral can be divided into two triangles the sum of the angles in a quadrilateral is also  $2 \times 180^\circ = 360^\circ$ .

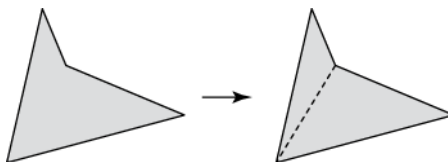

**b. Use a protractor, ruler, square, and compass to draw triangles and quadrilaterals from data given in either numerical or geometric form.**

- Draw a variety of triangles (right, isosceles, acute, obtuse) and quadrilaterals (squares, rectangles, parallelograms, trapezoids) of different dimensions.
- Verify basic properties of triangles and quadrilaterals by direct measurement.

**Note:** Verification by measurement requires many examples, especially some with relatively extreme or uncommon dimensions.

**Examples:** In parallelograms, opposite sides and opposite angles are equal; in rectangles, diagonals are equal.

*Example:* Cut any triangle out of paper and tear it into three parts so that each part contains one of the triangle's vertices. Notice that when the angles are placed together, the edge is straight ( $180^\circ$ ).

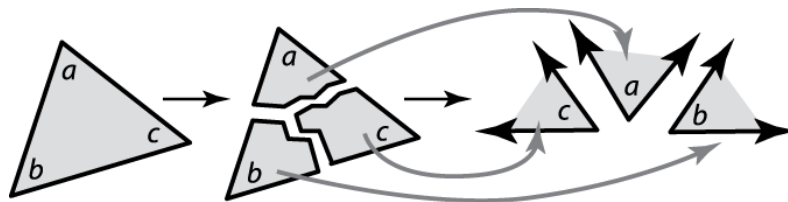

- Explore properties of triangles and quadrilaterals with dynamic geometry software.

**Note:** Is a parallelogram a trapezoid? It depends on the definition of trapezoid. If a trapezoid is defined as a quadrilateral with at least one pair of parallel edges, parallelograms become special cases of trapezoids. However, dictionaries usually define a trapezoid as a quadrilateral with exactly one pair of parallel edges, thereby

*distinguishing between parallelograms and trapezoids. Mathematicians generally prefer nested definitions as conditions become more or less restrictive. For example, all positive whole numbers are integers, all integers are rational numbers, and all rational numbers are real numbers. So in the world of mathematics, squares are rectangles, rectangles are parallelograms, and parallelograms are trapezoids.*

### **G.6.2 Understand and use the concepts of translation, rotation, reflection, and congruence in the plane.**

#### **a. Recognize that every rigid motion of a polygon in the plane can be created by some combination of translation, rotation, and reflection.**

- Translation, rotation, and reflection move a polygonal figure in the plane from one position to another without changing its length or angle measurements.
- Explore the meaning of rotation, translation, and reflection through drawings and hands-on experiments.

*Example:* The figure on the right illustrates how a rigid motion can be decomposed into a series of three steps: translation, reflection, and rotation.

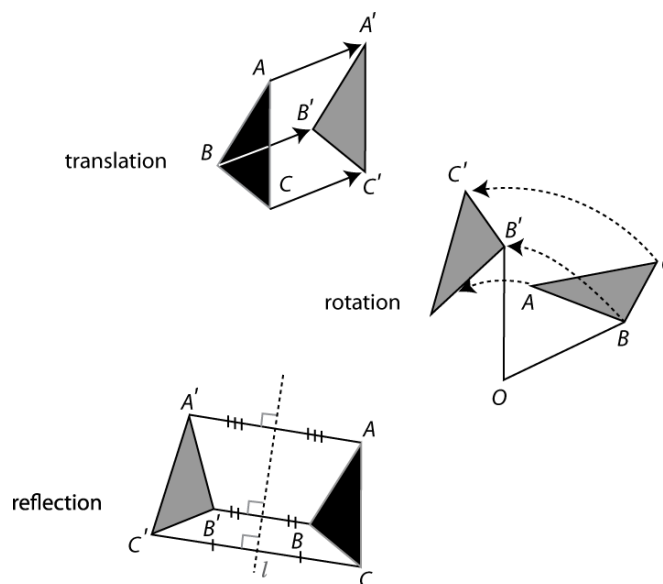

#### **b. Understand several different characterizations and examples of congruence.**

- Two figures in the plane are called *congruent* if they have the same size and same shape.
- Two shapes are congruent if they can be made to coincide when superimposed by means of a rigid motion.
- Two polygons are congruent if they have the same number of sides and if their corresponding sides and angles are equal.

**Note:** *Historically--beginning with Euclid--congruence applied only to polygons and used this as the definition. Indeed, the important properties of congruence are typically only about polygonal figures.*

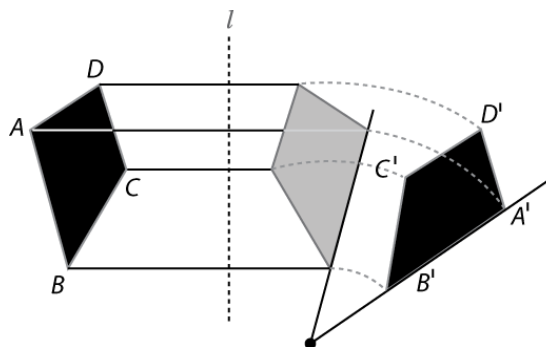

- Congruent figures in the plane are those that can be laid on top of one another by rotations, reflections, and translations.

**Note:** Using rotations, reflections, and translations to define congruence gives precise meaning to the intuitive idea of congruence as "same size and same shape," thus permitting a precise definition of congruence for shapes other than polygons.

**Note:** Technological aids (transparencies, dynamic geometry programs) help greatly in studying rigid motions.

**c. Identify congruent polygonal figures.**

- Understand why the two triangles formed by drawing a diagonal of a parallelogram are congruent.
- Understand why the two triangles formed by bisecting the vertex angle of an isosceles triangle are congruent.

**G.6.3 Understand and use different kinds of symmetry in the plane.**

**a. Symmetries in the plane are actions that leave figures unchanged.**

- Explore and explain the symmetry of geometric figures from the standpoint of rotations, reflections and translations.

**b. Identify and utilize bilateral and rotational symmetry in regular polygons.**

- A *regular polygon* is a polygon whose sides and angles are all equal.
- *Bilateral symmetry* means there is a reflection that leaves everything unchanged.
- *Regular polygons* have rotational symmetries.

**c. Identify and utilize translational symmetry in tessellations of the plane.**

- Most tessellations have translation symmetry.

**d. Use reflections to study isosceles triangles and isosceles trapezoids.**

- Understand why the base angles of an isosceles triangle are equal.
- Understand why the bisector of the angle opposite the base is the perpendicular bisector of the base.

**Note:** Draw an angle bisector on an isosceles triangle. Fold the drawing along the angle bisector (that is, reflect across the angle bisector). Then the base vertices collapse on each other: Both angles are equal, thus the angle bisector also bisects the base.

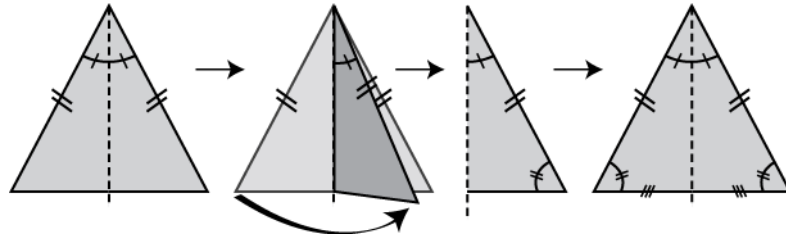

## Algebra (A)

### Kindergarten

#### A.K.1 Identify, sort, and classify objects.

##### a. Sort and classify objects by attribute and identify objects that do not belong in a particular group.

- Recognize attributes that involve colors, shapes (e.g., triangles, squares, rectangles, and circles) and patterns (e.g., repeated pairs, bilateral symmetry).

*Example:* Identify the common attribute of square in a square book, square table, and square window.

*Example:* Distinguish different patterns in ABABABA, .

##### b. Recognize related addition and subtraction facts.

- Use objects to demonstrate "related facts" such as  $7 - 4 = 3$ ,  $3 + 4 = 7$ ,  $7 - 3 = 4$ .

### Grade 1

#### A.1.1 Recognize and extend simple patterns.

##### a. Skip count by 2s and 5s and count backward from 10.

##### b. Identify and explain simple repeating patterns.

- Find repeating patterns in the discrete number line, in the 12 x 12 addition table, and in the hundreds table (a 10 x 10 square with numbers arranged from 1 to 100).

**Note:** Use examples based on linear growth (e.g., height, age).

- Create and observe numerical patterns on a calculator by repeatedly adding or subtracting the same number from some starting number.

##### c. Determine a plausible next term in a given sequence and give a reason.

**Note:** Without explicit rules, many answers to "next term" problems may be reasonable. So whenever possible, rules for determining the next term should be accurately described. Patterns drawn from number and geometry generally have clear rules; patterns observed in collected data generally do not.

#### A.1.2 Find unknowns in problems involving addition and subtraction.

##### a. Understand that addition can be done in any order but that subtraction cannot.

- Demonstrate using objects that the order in which things are added does not change the total, but that the order in which things are subtracted does matter.
- Use the fact that  $a + b = b + a$  to simplify addition problems.



**Examples:**  $2 + 13 = 13 + 2 = 15$  (by adding on);

$$7 + 8 + 3 = 7 + 3 + 8 = 10 + 8 = 18.$$

**Note:** *The relation  $a + b = b + a$  is known as the commutative property of addition. It reduces significantly the number of addition facts that need to be learned. However, the vocabulary is not needed until later grades.*

- Demonstrate understanding of the basic formula  $a + b = c$  by using objects to illustrate all eight number sentences associated with any particular sum:

*Example:*  $8 + 6 = 14$ ,  $6 + 8 = 14$ ;  $14 = 8 + 6$ ,  $14 = 6 + 8$ ;

$$14 - 8 = 6, 6 = 14 - 8; 14 - 6 = 8, 8 = 14 - 6.$$

### **A.1.3 Understand how adding and subtracting are inverse operations.**

#### **a. Demonstrate using objects that subtraction undoes addition and vice versa.**

- Subtracting a number undoes the effect of adding that number, thus restoring the original. Similarly, adding a number undoes the action of subtracting that number.  
Example:  $2 + 3 = 5$  implies  $5 - 2 = 3$ , and  $5 - 2 = 3$  implies  $2 + 3 = 5$ .

- Use the inverse relation between addition and subtraction to check arithmetic calculations.

**Note:** *Addition and subtraction are said to be inverse operations because subtraction undoes addition and addition undoes subtraction. However, this vocabulary is not needed until later grades.*

**Caution:** *Subtraction is sometimes said to be equivalent to "adding the opposite," meaning that  $5 - 3$  is the same as  $5 + -3$ . Here the "opposite" of a number is intended to mean the negative of a number. However, since negative numbers are not introduced until later grades, this formulation of the relation between addition and subtraction should be postponed.*

## **Grade 2**

### **A.2.1 Create, identify, describe, and extend patterns.**

#### **a. Fill in tables based on stated rules to reveal patterns.**

- Find patterns in both arithmetic and geometric contexts.

#### **b. Record and study patterns in lists of numbers created by repeated addition or subtraction.**

- Create patterns mentally (by counting up and down), by hand (with paper and pencil), and by repeated action on a calculator.

**Examples:** 3, 8, 13, 18, 23, ...; 50, 46, 42, 38, 34, ...

### A.2.2 Find unknowns in simple arithmetic problems.

#### a. Solve equations and problems involving addition, subtraction, and multiplication with the unknown in any position.

**Note:** *In the early grades, it is better to signify the unknown with a symbol, such as [ ], ?, or □, that carries the connotation of unknown rather than with an alphabetic letter such as x.*

#### b. Understand and use the facts that addition and multiplication are commutative and associative.

- Use parentheses to clarify groupings and order of operation.
- Recognize terms such as *commutative* and *associative*.

**Note:** *It is not necessary for children at this grade to use or write these words, merely to recognize them orally and to know the properties to which they refer.*

#### c. Recognize how multiplication and division are, like addition and subtraction, inverse operations.

### A.2.3 Understand basic properties of odd and even numbers.

#### a. Explain why the sum of two even numbers is even and that the sum of two odd numbers is also even.

- Use diagrams to represent even and odd numbers and to explain their behavior.

*Example:* The representation below shows that 14 is even and 13 is odd.

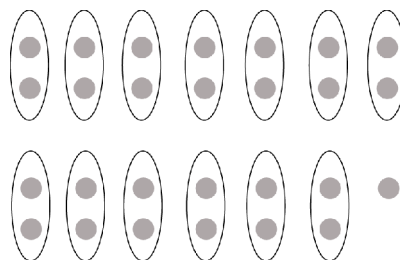

#### b. Answer similar questions about subtraction and multiplication of odd or even numbers.

## Grade 3

### A.3.1 Explore and understand arithmetic relationships among positive whole numbers.

#### a. Understand the inverse relationships between addition and subtraction and between multiplication and division, and the commutative laws of multiplication and addition.

- Show that subtraction and division are not commutative.

**b. Find the unknown in simple equations that involve one or more of the four arithmetic operations.**

**Note:** *To emphasize the process of solving for an unknown, limit coefficients and solutions to small positive whole numbers.*

Examples:  $3 \times ? = 3 + 6$ ;  $? \div 5 = 5 \times 55$ ;  $36 = ? \times ?$ .

**c. Create, describe, explain and extend patterns based on numbers, operations, geometric objects and relationships.**

- Explore both arithmetic (constant difference) and geometric (constant multiple) sequences.

Examples: 100, 93, 86, 79, 72, ...; 2, 4, 8, 16, ...; 3, 9, 27, 81, ... .

- Understand that patterns do not imply rules; rules imply patterns.

## Grade 4

### A.4.1 Use properties of arithmetic to solve simple problems.

**a. Understand and use the commutative, associative, and distributive properties of numbers.**

- Use these terms appropriately in oral descriptions of mathematical reasoning.
- Use parentheses to illustrate and clarify these properties.

**b. Find the unknown in simple linear equations.**

- Use a mixture of whole numbers, fractions, and mixed numbers as coefficients.

**Examples:**  $24 + n = n - 2$ ;  $3/4 + p = 5/4 - p$

**Note:** *"Simple" equations for grade 4 are those that require only addition or subtraction (e.g.,  $3/4 + [ ] = 7/4$ ) or a single division whose answer is a whole number (e.g.,  $3 \times [ ] = 12$ ).*

**Note:** *There is no need to use the term linear since these are the only kinds of equations encountered in grade 4.*

### A.4.2 Evaluate simple expressions.

**a. Find the value of expressions such as  $na + b$  and  $na - b$  where  $a$ ,  $b$ , and  $n$  are whole numbers or fractions and where  $na \geq b$ .**

- Make tables and graphs to display the results of evaluating expressions for different values of  $n$  such as  $n = 1, 2, 3, \dots$  .

**Note:** *Evaluating an expression involves two distinct steps: substituting specific values for letter variables in the expression, and then carrying out the arithmetic operations implied by the expression. Working with expressions both introduces the processes of algebra and also reinforces skills in arithmetic.*

**Note:** Avoid negative numbers since systematic treatment of operations on negative numbers is not introduced until grade 6.

**b. Evaluate expressions such as  $\frac{a}{b} + \frac{c}{nb}$ , where  $a$ ,  $b$ ,  $c$ , and  $n$  are whole numbers.**

**c. Evaluate expressions such as  $\frac{1}{a} + \frac{1}{b}$  where  $a$  and  $b$  are single-digit whole numbers.**

*Example:* The value of  $\frac{a}{b} + \frac{c}{nb}$  when  $a = 1$ ,  $b = 2$ ,  $c = 3$  and  $n = 4$  is  $\frac{1}{2} + \frac{3}{8} = \frac{4}{8} + \frac{3}{8} = \frac{7}{8}$ .

**Note:** Addition of fractions is limited to cases included in the grade 4 expectations—namely, unit fractions with denominators under 10 and other fractions where one denominator is a multiple of the other.

## Grade 5

### A.5.1 Find the unknown in simple linear equations.

**a. Equations that require only simple calculation should be solved mentally (that is, "by inspection"):**

$$96 + 67 = b + 67$$

$$\frac{3}{4} + \frac{5}{8} - \frac{5}{8} = p$$

$$a + \frac{3}{5} = \frac{3}{5}$$

$$39 - k = 39 - 40$$

$$\frac{3}{5} - \frac{3}{8} + \frac{5}{8} = d + \frac{3}{8} + \frac{5}{8}$$

$$\frac{1}{5} + \frac{2}{5} = b + \frac{6}{5}$$

$$78 + b = 57 + 79$$

$$53 + 76 = 51 + 76 + d$$

### A.5.2 Evaluate and represent simple expressions.

**a. Translate between simple expressions, tables of data and graphs in the coordinate plane.**

**b. Understand and use the conventions for order of operations (including powers).**

*Example:*  $ax^2 + bx = (a(x^2)) + (bx)$ , not  $(ax)^2 + bx$ .

**c. Evaluate expressions such as**

- $nr$  where  $n$  is a whole number and  $r$  is a fraction.
- $nab/(na-b)$  when  $n$ ,  $a$ , and  $b$  are whole numbers and where  $na > b$ .
- $\frac{a}{b} + \frac{c}{d}$  where  $a$ ,  $b$ ,  $c$ ,  $d$  are positive whole numbers.
- $\frac{1}{ab}$  where  $a$  and  $b$  are positive whole numbers.
- $\frac{a}{b}$  where one of  $a$  or  $b$  is a positive whole number and one is a fraction.

**Note:** Avoid expressions that introduce negative numbers since systematic treatment of operations on negative numbers is not introduced until grade 6.

**Note:** Working with expressions both introduces the processes of algebra and also reinforces skills in arithmetic.

**d. Understand the importance of not dividing by zero.**

**Grade 6**

**A.6.1 Understand that the system of negative and positive numbers obeys and extends the laws governing positive numbers.**

**a. The sum and product of two numbers, whether positive or negative, integer or fraction, satisfy the commutative, associative and distributive laws.**

- For any numbers  $a$ ,  $b$ ,  $c$ , (whether positive, negative or zero),  
 $a + b = b + a$ ,  $a \times b = b \times a$  (commutative);  
 $a + (b + c) = (a + b) + c$ ;  $a \times (b \times c) = (a \times b) \times c$  (associative);  
 $a \times (b + c) = (a \times b) + (a \times c)$  (distributive).

*Example:*  $(-3) \times 5 = -(3 \times 5)$ , because  $((-3) \times 5) + (3 \times 5) = ((-3) + 3) \times 5 = 0 \times 5 = 0$ . Hence the sum of  $(-3) \times 5$  and  $3 \times 5$  is 0, so  $(-3) \times 5 = -(3 \times 5)$ .

**Note:** This example can usefully be demonstrated on the number line in a way that avoids the formality of parentheses required above.

**b. Understand why the product of two negative numbers must be positive.**

- Since a negative number,  $-a$ , is defined by the equation  $-a + a = 0$ , the distributive law forces the product of two negative numbers to be positive.

*Example:* To show that  $(-3) \times (-5) = 3 \times 5$ , we demonstrate that the sum of the left side  $[(-3) \times (-5)]$  with the negative of the right  $[3 \times 5]$  is zero:

$$\begin{aligned} ((-3) \times (-5)) + (-3 \times 5) &= ((-3) \times (-5)) + ((-3) \times 5) \\ &= (-3) \times ((-5) + 5) = (-3) \times 0 = 0. \end{aligned}$$

The key middle step uses the distributive law.

**c. Understand why the quotient of two negative numbers must be positive.**

- Division is the same as multiplication by a reciprocal. If a number  $b$  is negative, so is its reciprocal  $1/b$ . So if  $a$  and  $b$  are both negative,  $a/b$  is positive since it equals the product of two negative numbers:  $a \times (1/b)$ .

*Example:* If  $p = -12/-3$ , then  $-12 = p \times (-3)$ . Since  $4 \times -3 = -12$ , this yields  $p = 4$ , hence  $-12/-3 = 12/3 = 4$ .

**A.6.2 Represent and use algebraic relationships in a variety of ways.**

**a. Recognize and observe notational conventions in algebraic expressions.**

- Understand and use letters to stand for numbers.
- Recognize the use of juxtaposition (e.g.,  $3x$ ,  $ab$ ) to stand for multiplication and the convention in these cases of writing numbers before letters.
- Recognize the tradition of using certain letters in particular contexts.

**Note:** *Most common:*  $k$  for constant,  $n$  for whole number,  $t$  for time, early letters ( $a$ ,  $b$ ,  $c$ ) for parameters, late letters ( $u$ ,  $v$ ,  $x$ ,  $y$ ,  $z$ ) for unknowns.

- Recognize different conventions used in calculator and computer spreadsheets (e.g.,  $*$  for multiplication,  $^$  for power).
- Understand and use conventions concerning order of operations and use parentheses to specify order when necessary.

**Note:** *By convention, powers are calculated before multiplication (or division) and multiplication is done before addition (or subtraction).*

*Example:*  $3x^2$  means  $3(x \cdot x)$ , not  $(3x) \cdot (3x)$ ;  $3x^2 - 7x$  means  $(3x^2) - (7x)$ , not  $(3x^2 - 7) \cdot x$ .

- Evaluate expressions involving all five arithmetic operations (addition, subtraction, multiplication, division, and power).

**Note:** *For the most part this is review. What is new is the introduction of powers and the shift to use of letters (rather than boxes, question marks, and other placeholders) to represent generic or unknown numbers.*

*Examples:*  $3x^2 - 7x + 2$ , when  $x = 3$  or  $1/3$ ;  $2x^{-3} + x$ , when  $x = 2$  or  $1/2$  or  $0$  or  $-3$ ;  $3x^2 - 2xy$ , when  $x = 2$  and  $y = 6$ .

**b. Solve problems involving translation among and between verbal, tabular, numerical, algebraic, and graphical expressions.**

- Write an equation that generates a given table of values

**Note:** *Limit examples to linear relationships with integer domains.*

- Graph ordered pairs of integers on a coordinate grid.

**Example:** *Prepare scatter plots of related data such as students' height vs. arm length in inches.*

- Generate data and graph relationships concerning measurement of length, area, volume, weight, time, temperature, money, and information.
- Understand why formulas or words can *represent* relationships, whereas tables and graphs can generally only *suggest* relationships.

**Note:** *Unless the rule for a table (or graph) is specified (e.g., in a tax table), the numbers themselves cannot determine a relationship that extends to numbers not in the table.*

**Note:** *The issue here is about the lack of precision inherent in a graph, not about the possibility, which is present in some graphs, of ambiguity concerning which of two very different points on the graph are associated with a given input value. The common example of ambiguity concerns the graph of the equation for a circle, but such graphs are not among those studied in grades K–8.*